

STARLOG presents

# CINEMAGIC

THE GUIDE TO FANTASTIC FILMMAKING

\$1.95  
95P

TM

Number 22

## Re-creating 'Star Wars' Creatures

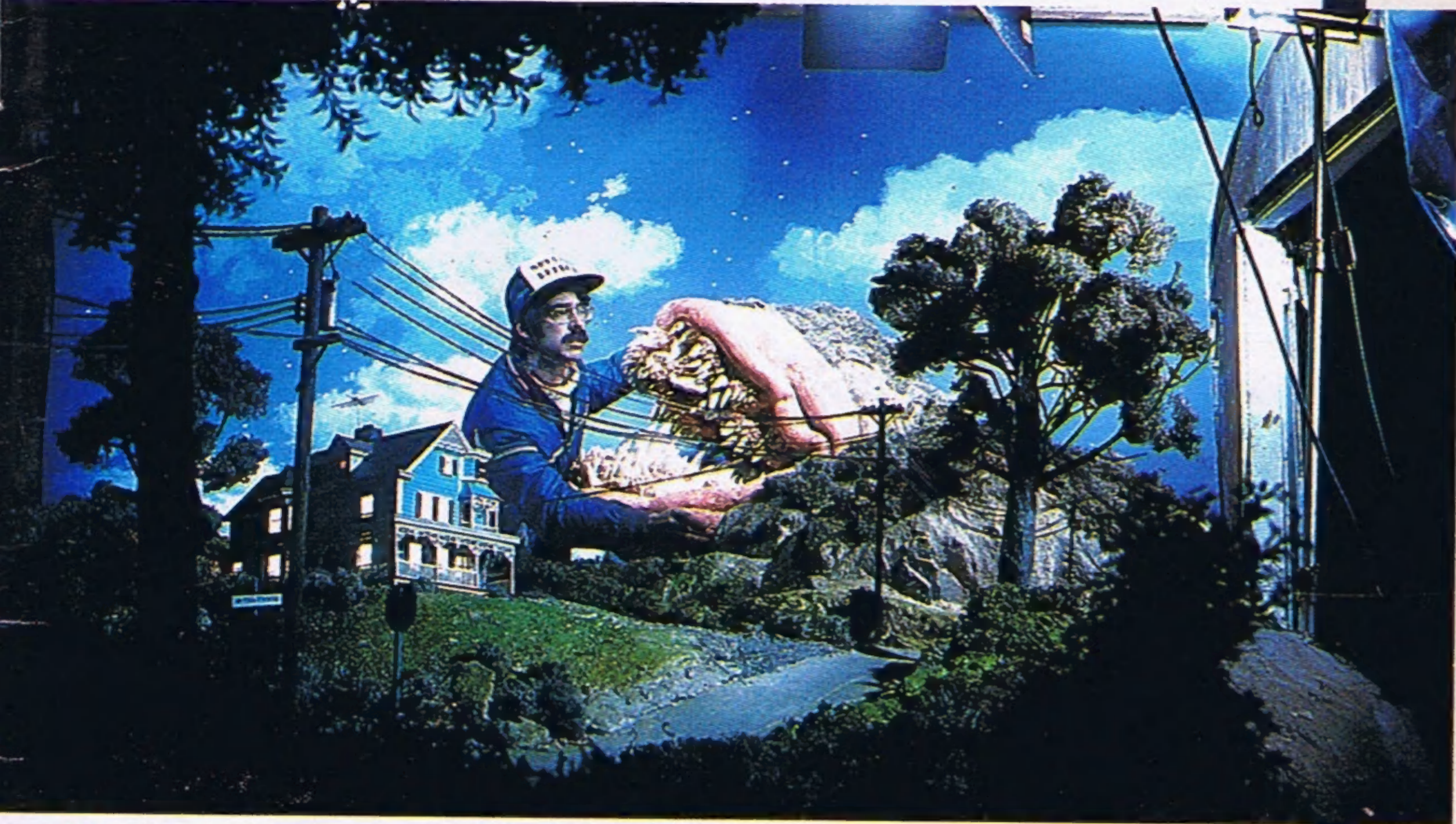

## Super Low-Budget Miniature Landscapes

'Extended Play' The 16mm short  
that has won an incredible  
49 awards!



**Also: Build Your Own Title Spinner**  
**New Section: Stopmotion Studio**  
**Special FX: Super Flash**



**Above left:** An animation model of an ant sits in a latex casting of a hand in a scene from *Extended Play*, the 16mm short that won first prize in last year's CINEMAGIC/SVA Short Film Search and has won 48 other film festival awards. The ant model is only  $\frac{3}{4}$ -inch high and required the use of surgical tweezers to animate. See the story of the making of *Extended Play* in the Profile on page 22. **Above right:** Alan Stacy creates the head of an alien creature. The costume will include a full body suit. See "Making Men into Beasts" on page 32. **Below:** more scenes from *Extended Play*, (page 22).



**Editor's Bench** \_\_\_\_\_ **4**

**Miniature Landscapes** \_\_\_\_\_ **6**

Create a neighborhood on a table top. By John Dods.

**Filmmakers' Forum** \_\_\_\_\_ **10**

A regular department devoted to readers' comments and correspondence about fantasy filmmaking.

**Electronic Special Effects** \_\_\_\_\_ **12**

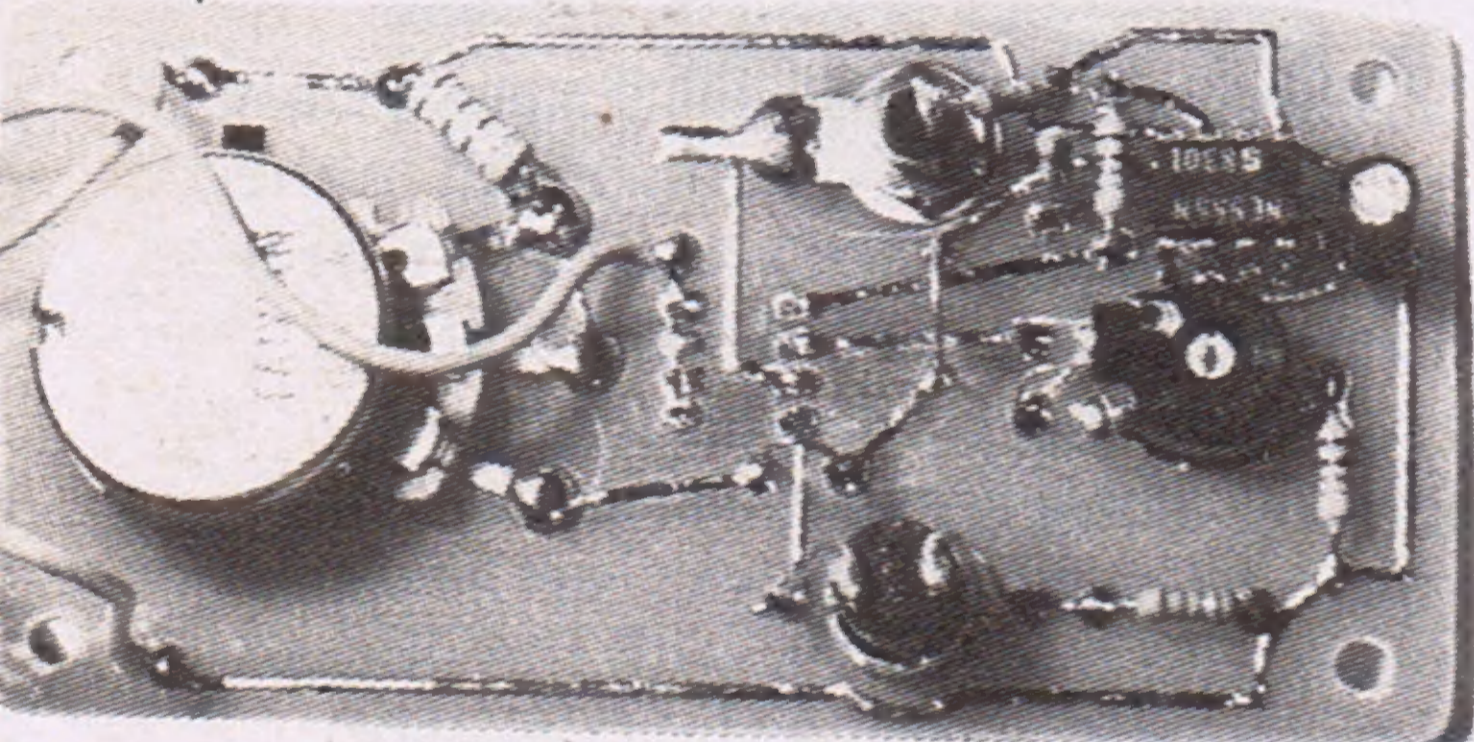

Accessories for the sync strobe unit described in issue #20. By Chris E. Stevens.

**Producers' Bulletin Board** \_\_\_\_\_ **16**



Latest news of our readers' productions.

**Cinemagic Marketplace** \_\_\_\_\_ **17**

Classified advertising and announcements.

**Vertigo Effect** \_\_\_\_\_ **18**

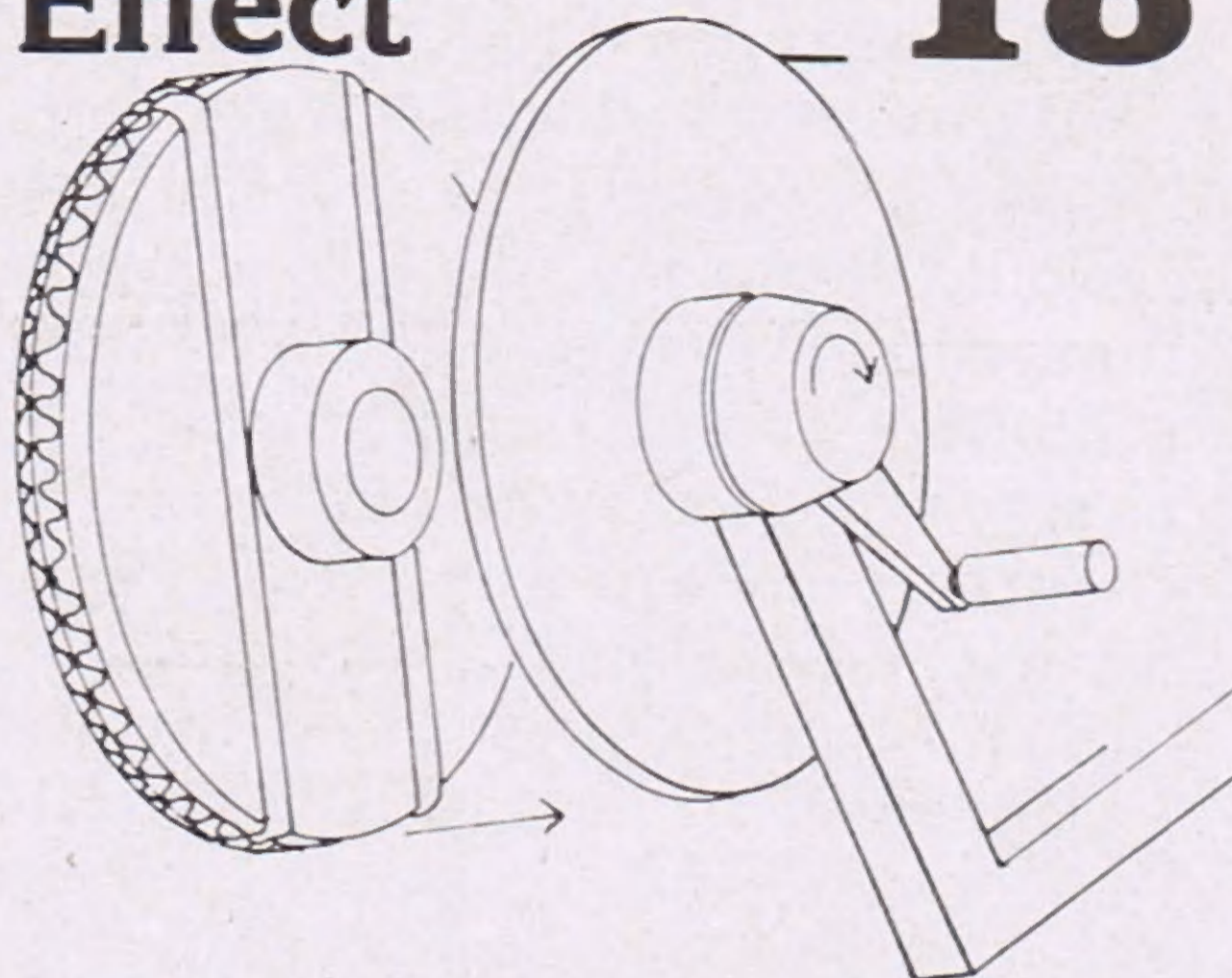

Build this easy-to-construct title spinner and throw your audiences for a loop. By Jack Imes, Jr.

**Stop-Motion Studio** \_\_\_\_\_ **20**

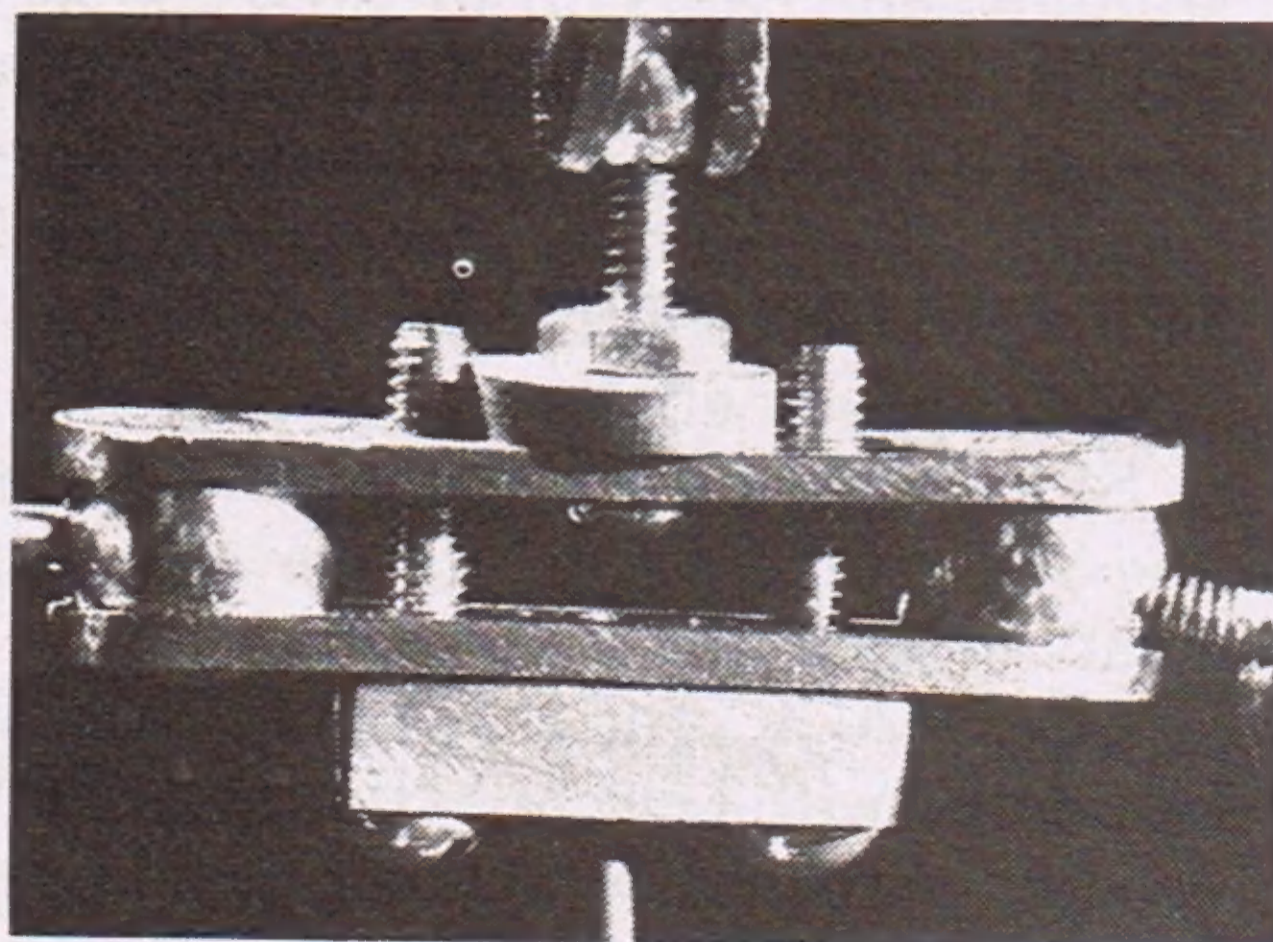

John Dods spotlights Ken Brilliant's precision ball-and-socket armature.

**Profile** \_\_\_\_\_ **22**



Director David Casci talks about the making of his award-winning film, *Extended Play*. By John Clayton.

**"Lights! Camera! Action!"** \_\_\_\_\_ **28**



"Standby . . . Lights! Camera! Action!" is a cable TV show hosted by Leonard Nimoy on the Nickelodeon channel that is of special interest to filmmakers.

**Grip Kit** \_\_\_\_\_ **30**



Useful accessories for filmmakers.

**Books** \_\_\_\_\_ **31**

Books for filmmakers—valuable sources of information and technique for the filmmaker.

**Men into Beasts** \_\_\_\_\_ **32**



Recreating *Star Wars* creatures and designing an original werewolf. By Alan Stacy.

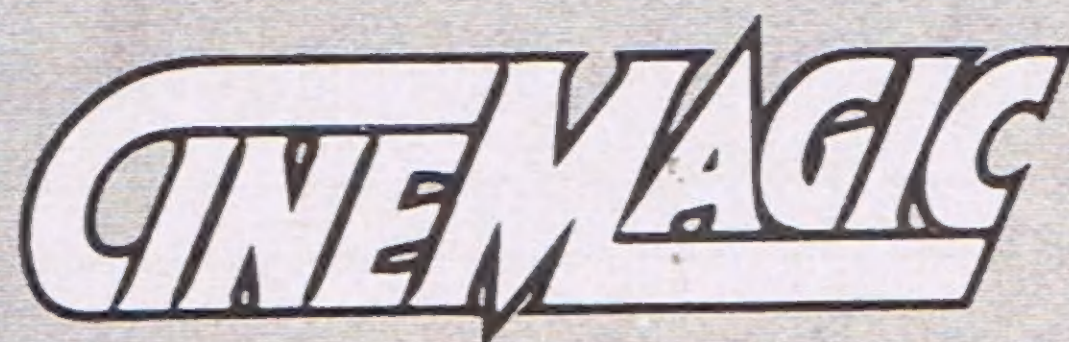

Issue #22

**Publishers**

Norman Jacobs/Kerry O'Quinn

**Associate Publisher**

Rita Eisenstein

**Circulation Director**

Richard Browne

**Assistant Publisher**

Milburn Smith

**Editor**

David Hutchison

**Art Director**

W.R. Mohalley

**Managing Editor**

John Clayton

**Associate Art Director**

Neal Holmes

**Senior Designer**

Denise Lewis

**Designers**

Daniel Abello

Sook Han

**Editorial Contributors**

David A. Casci

John Dods

Jack Imes, Jr.

Alan Stacy

Chris E. Stevens

**Production Assistants**

Ed Berganza

Richard Cepek

Eileen Dempsey

Norma Garcia

Chris Kwiath

Andrea Passes

**Financial Manager**

Joan Baetz

**Founder of CINEMAGIC**

Don Dohler

**Published by**

STARLOG PRESS, INC.

475 Park Ave. South

New York, NY 10016

Advertising Information: Rita Eisenstein  
(212) 689-2830

**About the cover:** The Chewbacca character from *Star Wars* was re-created by Alan Stacy. See page 32. The man with the monster on the miniature set is John Dods. See page 6. The very distraught-looking man is John Pierce in *Extended Play*. See page 22.

**Editor's**

# BENCH

## Secret Plans Revealed?

**S**ometimes I think there must be a spy in my office.—a "John LeCarre mole" who looks over my shoulder. This morning I received a letter from CINEMAGIC reader T. Chris Martindale of Bloomington, IN who writes: "I would like to see a TV program based on the CINEMAGIC concept of SPFX filmmaking. Such a program would discuss and give demonstrations of sculpting, stop-motion, armature design, matte painting, optical effects, as well as serving as a showcase for Short Film Search winners giving the rest of us a chance to view these lauded entries. I think it would prove to be greatly entertaining and a boon to amateur filmmakers everywhere."

So how does Chris know so much about what has been a topic of discussion around the CINEMAGIC offices for the past six months? Well, of course, we all think it is a great idea. But what about the audience? Who is going to watch it? The number of interested high school and college filmmakers in the United States is not sufficient to support such an undertaking. In order to be successful the show must reach and interest non-filmmakers—fans of the genre who are interested in finding out how other people do things, but have no real intention of actually making a film themselves, the ones that I call armchair filmmakers.

One of my early proposals for such a TV show was based on PBS's incredibly successful series *This Old House*. Our show would take place on location in the midst of production of some film preferably an amateur CINEMAGIC film or a 16mm super-low-budget independent effort. Each show would run for 30 minutes and concentrate on some aspect of the production. One segment might focus on how a miniature set was coming along and then stop to interview the cinematographer about his approach to a scene that was just about to be shot. We would be able to watch a few takes and then speak with the director afterward to see if things had gone as planned and if not what they thought could be done about it.

Since that early proposal, the project has grown to include segments with the SFS winners and interviews on camera with the filmmakers as Chris suggests in his letter.

CINEMAGIC was able to take a small step in this direction, recently when we appeared with Leonard Nimoy on his show *Stand By: Lights, Camera, Action*. Audience response to this guest appearance will certainly influence future plans.

—David Hutchison

### AWARDS NIGHT!

The annual CINEMAGIC/SVA Short Film Search Awards Night has been scheduled for the evening of November 7. The location has not been definitely scheduled. But if you are interested in attending, send a S.A.S.E. to CINEMAGIC AWARDS NIGHT, 475 Park Avenue South, 8th floor, New York, NY 10016 for your personal invitation with all of the details.

CINEMAGIC is published bi-monthly by STARLOG PRESS, INC. 475 Park Avenue South, New York, NY 10016. This is issue #22 (Volume 4, No. 4). ISSN #0090-3000. Content is © 1983 by STARLOG PRESS, INC. All rights reserved. Reprint or reproduction of any material in part or in whole without written permission from the publishers is strictly forbidden. CINEMAGIC accepts no responsibility for unsolicited manuscripts, photos, art or other material, but if freelance submissions are accompanied by a self-addressed, stamped envelope, they will be considered and, if necessary, returned. Products advertised are not necessarily endorsed by CINEMAGIC, and any views expressed in editorial copy are not necessarily those of CINEMAGIC. Subscription rates: \$9.98 for one year (six issues) delivered in the U.S., Canada and Mexico, foreign subscription \$12.98 in U.S. funds only. **New Subscriptions:** send directly to CINEMAGIC, c/o STARLOG PRESS, INC., 475 Park Avenue South, New York, NY 10016. Notification of **Change of address** or **renewals** send to CINEMAGIC, Subscription Dept. P.O. Box 142, Mt. Morris, IL 61054-0142. **Postmaster:** Send address changes to CINEMAGIC, 475 Park Ave. So., New York, NY 10016. Application to mail second class is pending at New York, New York and other locations. Printed in U.S.A.

# WORLDS OF IMAGINATION

From

## STARLOG PRESS

Travel through a universe of wonder, laughs and chills with these marvelous STARLOG magazines!

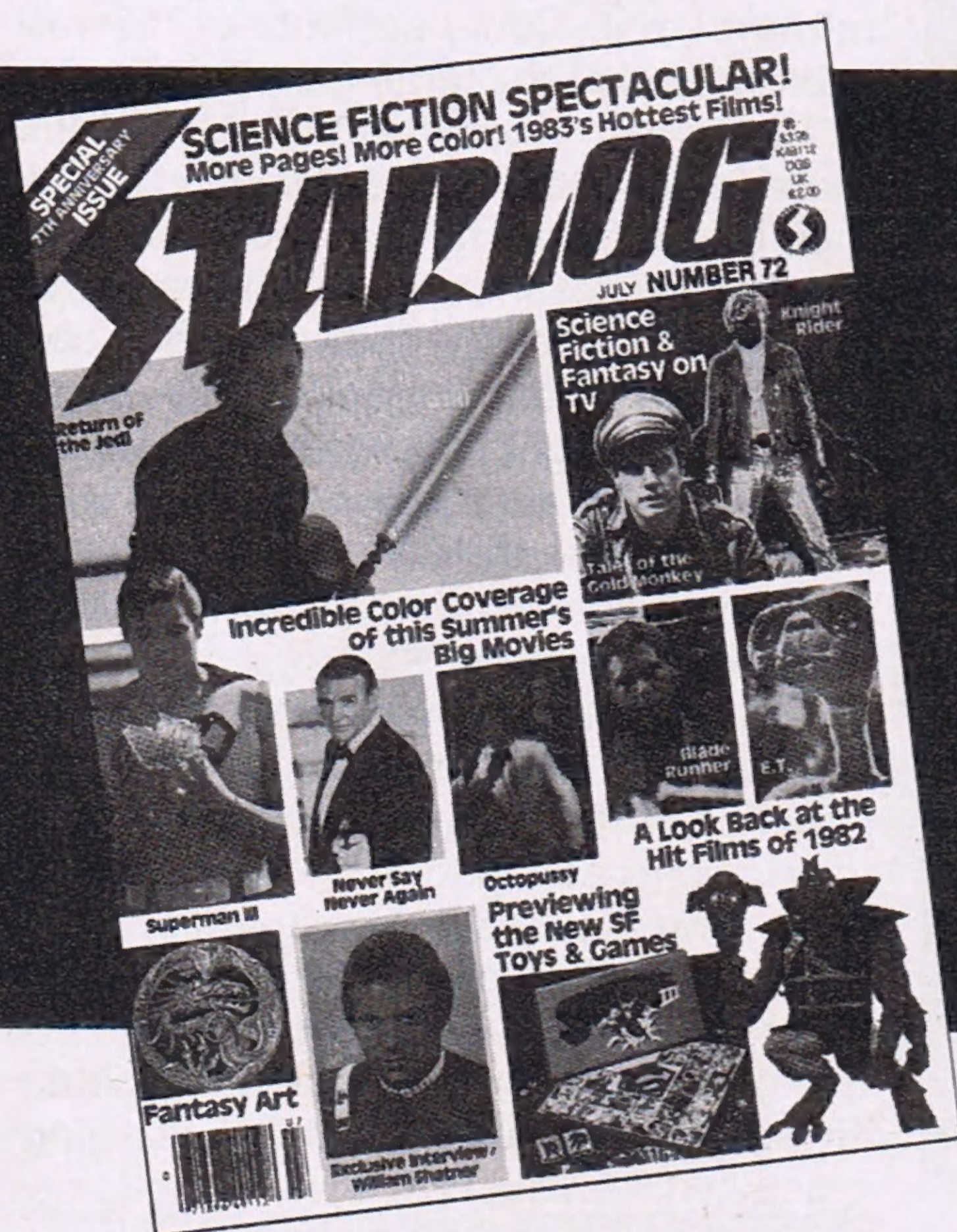

### STARLOG—

The most popular science fiction magazine in our solar system, bringing you all the latest in SF film, television and fact!

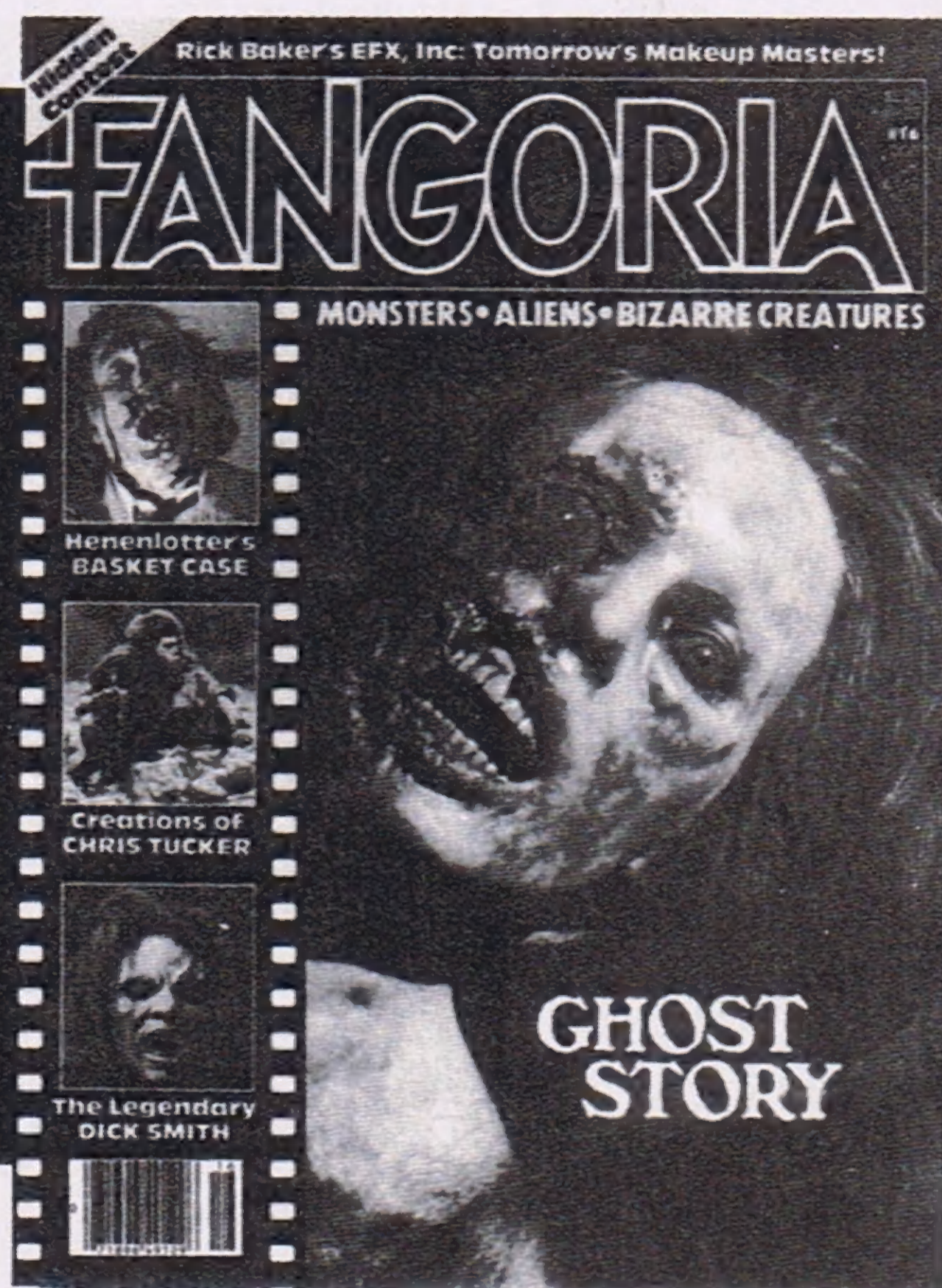

### FANGORIA—

The magazine of motion picture thrills, chills and horror, for all you brave souls with a taste for terror!



### CINEMAGIC—

If you are a young filmmaker interested in science fiction, special effects and the magic of the cinema, this is your magazine!

**Explore the outer reaches of fun & imagination!**

**Look for these exciting publications at your local newsstand—or subscribe today!**

Mail to: STARLOG PRESS, 475 Park Avenue South, New York, New York, 10016

\_\_\_ STARLOG \$27.49  
(12 issues/year)  
Foreign: \$36.49

\_\_\_ FANGORIA \$15.98  
(8 issues/year)  
Foreign: \$21.98

\_\_\_ CINEMAGIC \$9.98  
(6 issues/year)  
Foreign: \$12.98

Enclosed: \_\_\_\_\_

NAME \_\_\_\_\_

ADDRESS \_\_\_\_\_

CITY \_\_\_\_\_ STATE \_\_\_\_\_ ZIP \_\_\_\_\_

Allow 7 to 9 weeks for first delivery. Foreign subscriptions, U.S. funds only.

# Table Top Worlds

Create your own fantasy world  
on a miniature set in your basement studio.

By JOHN DODS



Special effects artist Glenn Takajian strings a "power line" to the miniature house he created for the closing shot in *The Deadly Spawn*. The miniature house is a faithful recreation of the real location house. The road is roofing paper cut to size and cemented into place. The vegetation and tree tops are lichen.

It was a real problem. How were we going to create the biggest effect of the entire production without any money—well, *hardly* any money? It was near the end of the filming on *The Deadly Spawn* when Executive Producer Tim Hildebrandt and Producer Ted Bohus had their brainstorm. They wanted to cap the film with a shot showing just how big the ever-growing deadly spawns really can get—as big as a mountain. Dino D'Laurentis might have spent a couple of million dollars on a mountain-sized construction, but with less than \$500.00 to spend we had to think small. So, naturally, we built a miniature.

Tim Hildebrandt's production drawing for the shot was our guide during construction as well as our inspiration to do the work necessary to make it happen on film. Tim's teenage experience as a miniature landscape builder, as well as his more recent work on the 3M TV commercial (the one with the futuristic looking cityscapes), was instrumental in realizing



PHOTO: JOHN DODS

Plywood supports are covered with chicken wire to create the basic topography. This is then covered with paper toweling and cement (seen in right foreground).

the drawing. Tim in fact did all the landscape detailing himself. The rest of our effects crew for this shot included Glenn Takakjian who built the house, Frank Balsamo—cinematographer, Greg Ramundas—*Deadly Spawn* chief effects technician, and Robert R. Bohus. As usual, it was my job to build the monster.

## BUILDING THE SET

Before doing any actual construction we cut shapes out of cardboard representing various proposed set elements. When viewed through the camera, these helped us to determine how big and how deep we would have to make the set in order to get the depth of field we wanted. This turned out to be about 10 feet wide by 15 feet deep. Plywood cutouts then replaced the cardboard so that the set would have a sturdy substructure. Chicken wire covered the plywood and was shaped to create the basic topography of the landscape. The chicken wire was covered with paper toweling and a low budget substitute for plaster: cement. A ¼-inch thickness provided the strength needed.

Chunks of burnt coal from the Hildebrandt's coal stove were pressed into the cement to form cliffsides and other rocky looking areas. Coal dust (from the same source) and flocking—applied with a flour sifter—created areas of texture and color. Lichen—a spongy fungus growth—was used to simulate areas of vegetation and the tree tops. Lichen can be purchased where toy train accessories are sold, though it can be found growing naturally in places having good air quality. I “imported” a hefty bag full of it (about \$300.00 worth) on my way back from a trip to Ontario, Canada. Trees were made of real tree branch endings—sometimes bunched together and taped along the “trunk” section before being painted. [See Dod's article on constructing miniature trees in CINEMAGIC #3.]

A road was cut out of roofing paper and cemented into place. The gravel at the side of the road was kitty litter.

## THE HOUSE

Glenn Takakjian's efforts in producing a scaled miniature house topped that of everyone else on the crew combined. Working 4-5 hours a day for 6 weeks, Glen produced a highly detailed accurate miniature version of the *Deadly Spawn* primary location; a house.

Glen began by taking many photos of the house he was to copy; long shots and many close ups of detailing. The construction began with the assembly of a corrugated cardboard framework with holes being cut wherever windows were needed. Proportions were determined by studying the photos.

Floor by floor, the cardboard substructure was covered with balsawood “siding” using Elmer's glue as an adhesive. The window frames were also made of balsa

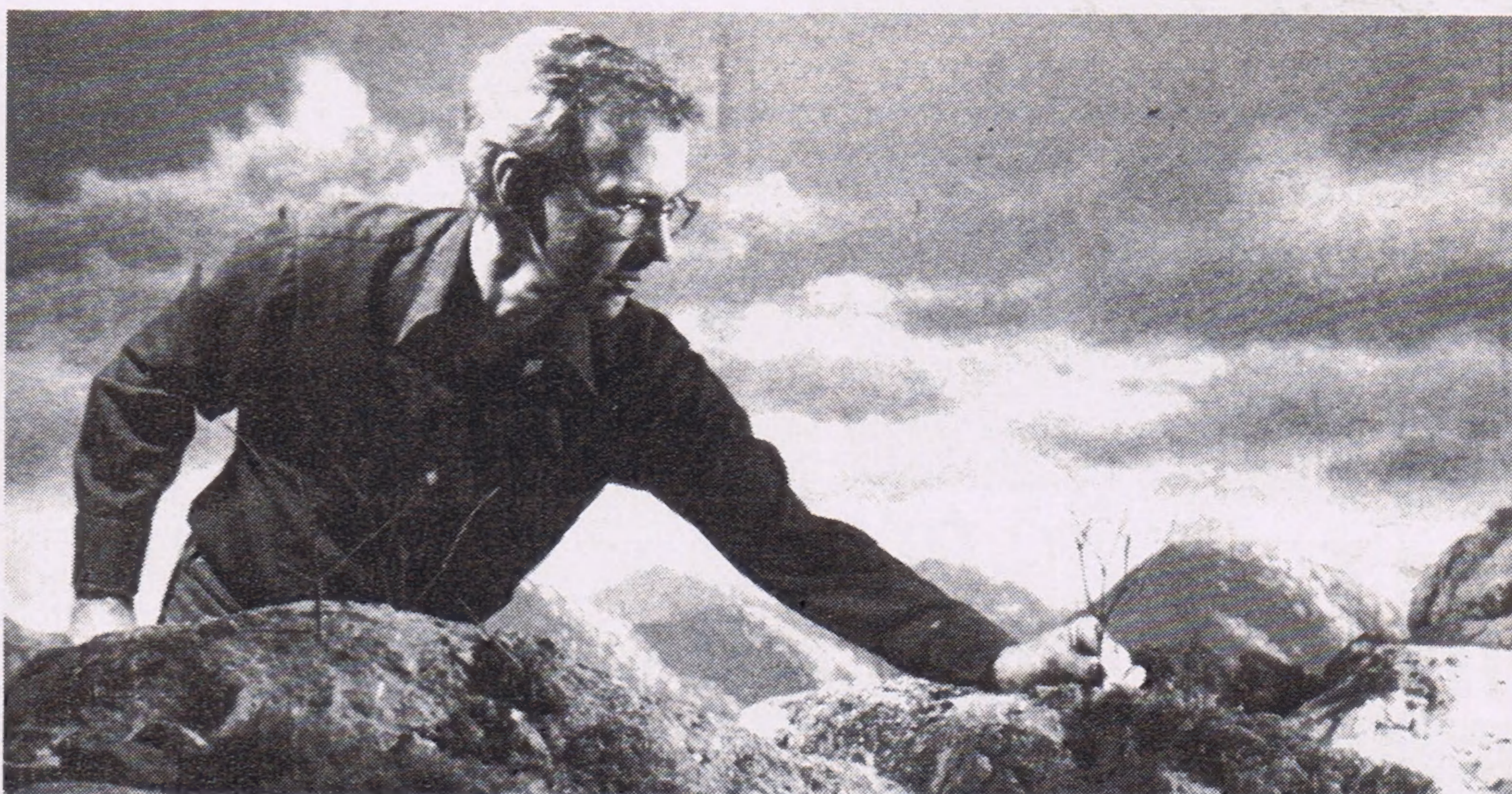

PHOTO: JOHN DODS

Artist Tim Hildebrandt, who designed the miniature sets and painted the “sky” background, begins to detail one of the miniature sets constructed for *The Deadly Spawn*. Tim's teenage experience as a miniature landscape builder, as well as his more recent professional experience, was instrumental in realizing his designs.

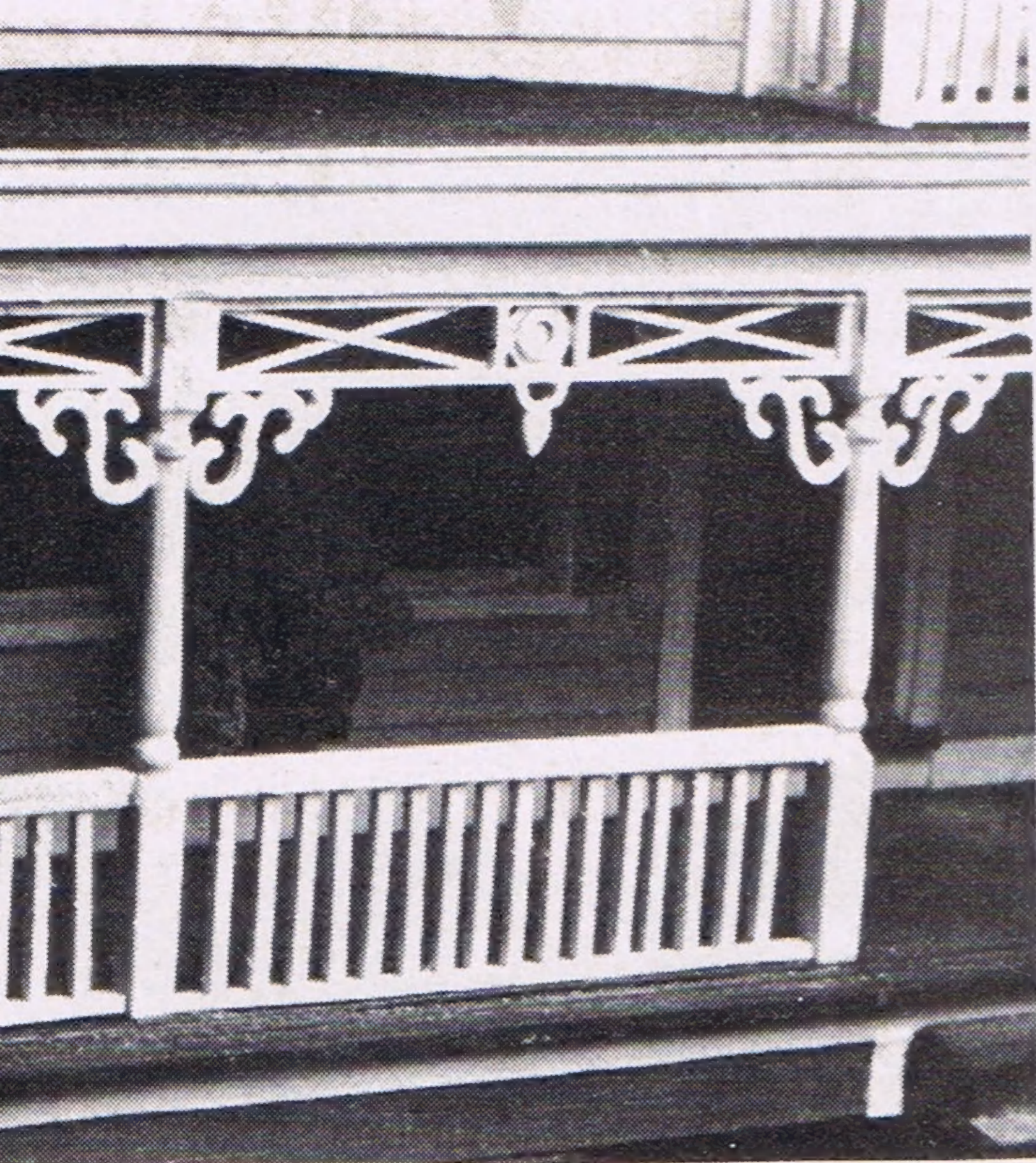

PHOTO: TIM HILDEBRANT

**Above:** Author John Dods tests the giant “Deadly Spawn” control mechanism, which operates like a giant pair of scissors. Two crew members operated the mechanism during the shot. The bulk of the monster's shape was made of chicken wire covered with foam rubber strips stapled together. The skin was built up with paper toweling covered with latex rubber. This helped to minimize the weight of the monster. **Below:** Tim Hildebrandt and John Dods confer on the miniature set that they built for *The Deadly Spawn*.



PHOTO: TIM HILDEBRANT



**Left:** Vertical posts were bought at a doll house supply and modified with a dremel tool. Curved "gingerbread" shapes were pieced together from a dismantled doll house gate to match detailing on the real house.

with molding detail being hand carved using an exacto knife; this was sanded with fine grade emory cloth. Clear plastic was placed behind the windows to simulate glass.

The large vertical posts of the downstairs porch were purchased from a doll house supplier and modified using an electric Dremel tool. The "gingerbread" ornamentation was reconstructed from parts of a doll house gate—each "S" shaped unit being made of 4 plastic pieces that had been cut, glued, and sanded. The smaller posts as well as the rest of the porch construction was simply hand carved using an exacto knife and a great deal of care.

The completed porch construction was coated with a plastic spray in order to smooth over and hide the grain texture of the balsa wood. The plastic surface also made it possible to use instant bonding Crazy Glue as an adhesive instead of the

slow drying Elmer's.

The chimney was a balsa wood box covered with ordinary wall spackle. Bricks were carved into the dry spackle using the end of small rat tail file.

Covering the cardboard roof with 1,200 shingles was the most time consuming part of the project. Each shingle was individually cut from thin cardboard and glued into place.

The completed house was painted with acrylic paints.

## THE MONSTER

In the shot we were planning the monster—or monster head—had to first look like a distant mountain, and then to rise upwards, tilt up, and open its mouth. Since we had determined that the head had to be a rather large construction—3 feet wide, 3 feet high, and 4 feet long—it required a very substantial control mechanism to make these movements happen. This was constructed out of wood—2x4's and plywood. A seasaw arrangement—the head being at one end of the seasaw—controlled the upward move-

**Below:** A balsa wood chimney was covered with a thin coat of wall spackle. The dry spackle was then carved to create the look of bricks on the chimney.

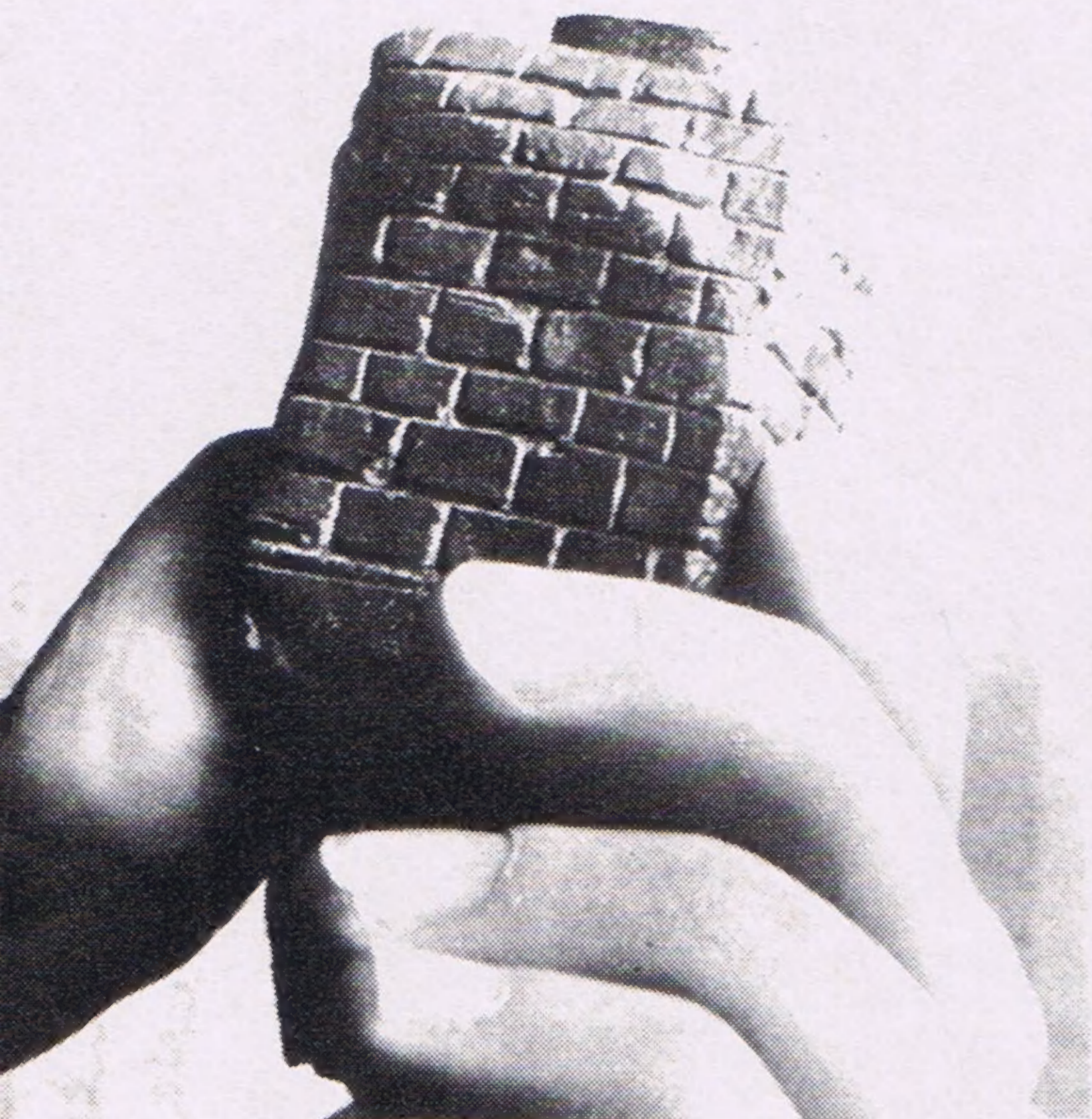

**Below:** Glenn Takakjian cut each roof tile individually out of thin cardboard and used "Elmer's" glue to secure each individual tile to the roof.

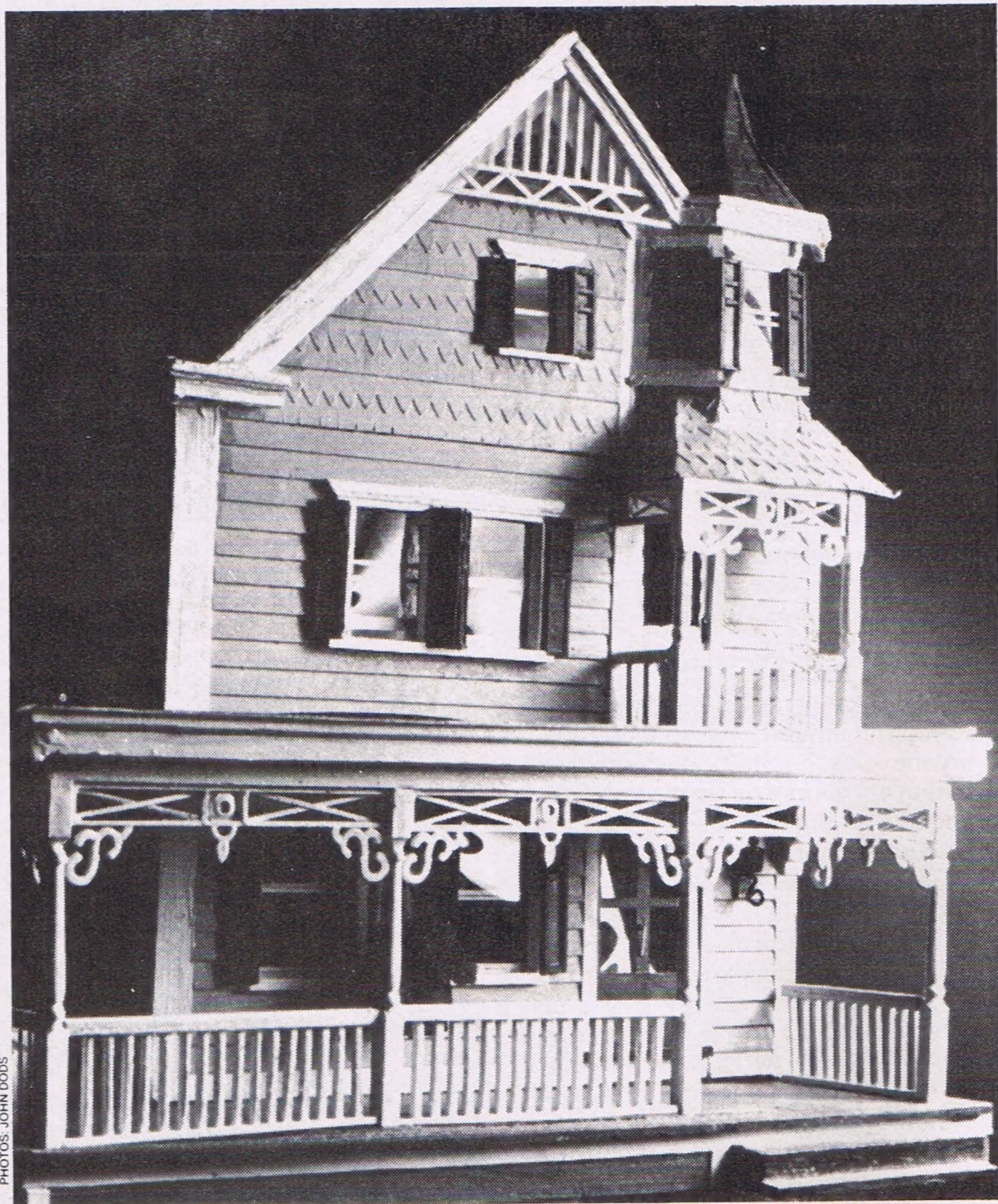

**Above:** The cardboard substructure was covered, floor by floor, with balsa wood siding. The "glass" in the windows is clear plastic. Working from photos, Glenn Takakjian spent six weeks making the miniature house.



PHOTO: CHARLES HILDEBRANDT



The opening shot in *The Deadly Spawn* made use of the same miniature landscape as the closing shot, except that the house was not seen in the opening shot. This shot also featured a projected lightning bolt.

ment. A 10 feet long handle attached to what amounted to 2 oversized pairs of scissors caused the mouth to open. This handle also governed the tilt of the head.

The mountain monster's gums and numerous teeth were cast in hydrocal (a hard plaster) using existing rubber molds produced earlier for other spawn constructions in the movie (See "Making Monsters" in CINEMAGIC #18.) These teeth—fragile but cheap to produce—were wired to the substructure. Many of the smaller teeth were simply painted onto the gums. The bulk of the shape was made of chicken wire and sheets of foam rubber (stapled together); the use of these materials helped minimize the weight of the construction. Finally, the monster's skin was built up out of paper toweling and liquid latex rubber. The creature's head was landscaped with burnt coal chunks and lichen in the manner of the rest of the set.

### THE BACKDROP

Everything we built was backed up by an original Hildebrandt painting. Three panels of masonite were joined together and taped at the seams with gafers tape to provide a large canvas. The sky actually had to be painted three times. The oil based paint first used proved to be too reflective—it was impossible to light. Tim opted for redoing it rather than trying (expensive) experiments with large amounts of dulling spray. The second version—painted in flat latex base wall paints—is

the one seen in the film. Still another backdrop was painted when we decided to use the miniature—minus house and somewhat modified—for the shot that opens *Deadly Spawn*; a meteorite crossing the sky and falling to earth.

Ideas on how to produce stars in the night sky ranged from direct projection, to the use of bits of front projection material or sequins. The first thing we tried worked—almost unexpectedly—so we used it: Tim simply painted them on.

### FILMING THE SHOT

We knew from the beginning that we wanted to film the shot in slow motion in order to suggest great size in the creature as an avalanche of dirt and rocks (burnt coal chips and coal dust mostly) fell away from its rising body at a speed right for its apparent size. We were able to shoot at 64 frames per second (only about half of what we would have liked.) This rapid rate of frame exposure increased our lighting requirements as did stopping down the lens to increase the depth of field on the set. It ended up that <sup>2</sup>/<sub>3</sub> of the money we spent on the shot was spent renting lights (about 8000 watts) and extension cords. The final bill for the shot was about \$360.00.

Our shot wasn't made so much with money as it was with effort and enthusiasm. While making *The Deadly Spawn* we learned that while dollars are important, ingenuity and resourcefulness are *more* important. They really are. I've got the footage to prove it.



With this year's release of two new James Bond Films, *Never Say Never Again* and *Octopussy*, *The James Bond Films*, in a new updated edition, is indispensable reading for all 007 enthusiasts!

One hundred and sixty black-and-white photographs illustrate this updated behind-the-scenes look at the making of all the exciting James Bond films, including *Dr. No*, *Goldfinger*, *Diamonds Are Forever*, and *Live and Let Die*, to name just a few.

*The James Bond Films* describes how the scripts were written, gives the secrets behind the breathtaking stunts, tells how the famous Bond gadgets were devised, and how the great sets were created. It profiles the various actors and actresses who appeared in the Bond Films and provides an insight into Ian Fleming, the James Bond creator. For this "insider's" information, the author conducted scores of interviews with producers, directors, writers, actors, and technicians connected with the Bond movies. The result is this revealing and intimate look at the *real* world of James Bond.

Clip or Copy

Send cash, check or money order to:  
**STARLOG PRESS**  
475 Park Avenue South  
New York, NY 10016

Please send me \_\_\_\_\_ copies of  
**THE JAMES BOND FILMS.**

\$17.95 hardcover

Please add \$1.70 postage and handling for each book ordered.

NAME

ADDRESS

CITY

STATE

ZIP

Allow 4 to 6 weeks for delivery.

# Filmmakers' FORUM

A regular department devoted to readers' comments about filmmaking, their problems and solutions.

Contact filmmakers in your area! You can contact filmmakers whose work interests you or who happen to live in your area, simply by writing to them at the addresses listed with their letters. CINEMAGIC encourages filmmakers to contact each other and possibly collaborate on projects. For more names and addresses, see Producers' Bulletin Board, page 16.



King Kong™ recently returned "home" to Robert Keith & Co. in San Diego from a five-day stay at the "Fabulous Fox" Theater in St. Louis, where his hosts held a birthday celebration for the giant inflatable ape in honor of the 50th anniversary of his celluloid birth.

## Grossed Out by Gore

... I have been noticing with increasing disgust, the large number of films appearing in Producers' Bulletin Board featuring gratuitous violence and gore.

Frankly, I can't see why these films are being made. Movies are supposed to be entertaining. What's entertaining about blood-splattered corpses, decapitations, or mass murders? The only people these films can entertain are psychopaths or murderers. So, if the films have no entertainment value, why make them?

Not only are these gore films not entertaining, but they are mostly unoriginal. How many times have I heard about movies that feature psychotic killers, murderous demons, or blood-thirsty mutants? Too many.

Either these filmmakers are too lazy or not inventive enough to create a movie with semblances of originality and entertainment. If these people are the filmmakers of tomorrow,

God help the industry! We'll be seeing the likes of *Halloween 20* or *Motel Hell: Part 10!*

**Grant Van Groenigen**  
226 Wilfred Ave.  
Willowdale, Ontario  
Canada  
M2N-5E3

## Starfield Backgrounds

... I have a problem: Shooting and getting enough exposure on my film for filming a space adventure, *Legoland Space the Motion Picture*, and I need to get some ideas to get points of light to show up on film.

**Andrew Petterson**  
Rt 8 Box 268  
Tucson, AZ 85730

... Try shooting a black velvet cloth (velour is cheaper) with tiny holes punched through it with a strong back light. Don't let any light fall on the front side of the cloth, but let the strong backlight burn brightly through the pin holes in the cloth. Be careful to keep the cloth a safe distance

from the backlight. The cloth could burn and ignite if it comes in contact with the hot lights. You could even tape tiny pieces of different colored gels behind the starholes to suggest the many types of stars in the cosmos, such as red giants and blue dwarfs. Experiment until you get the results you want.

## Negative Super-8?

... I'm writing for advice on some problems that I encountered recently. I have built both the camera crane (CINEMAGIC #16) and the Optical printer (CINEMAGIC #'s 4 & 5), thanks to the informative how-to articles in CINEMAGIC. I have achieved excellent results with both of these devices. My problem lies with too much time and money spent preparing cels for the optical printer. I've thought of a good solution, but have no way of executing it. Instead of using painted cels, I would draw with a pencil on white paper, then animate these on a negative film stock, giving me a white (laser) line against a black background. This would then be added to the original footage, giving me the final effects shot. This method would

save a tremendous amount of time, since it is easier to draw an effect than it is to meticulously paint one. Yet, unfortunately, I can't get a hold of a negative film stock in Super-8. Perhaps someone could help me locate some of this (if it exists)? It would be greatly appreciated.

**Edward Quirk**  
44 Mayflower Rd.  
Levittown, PA 19056

## CINEMAGIC Writer's Guide

... The CINEMAGIC Writer's Guide is now available. If you have an article in mind for CINEMAGIC and would like to know what we expect to see from our writers, send a self-addressed, stamped envelope (business #10 size) to the address below.

**CINEMAGIC Writer's Guide**  
475 Park Ave. So.  
New York, NY 10016

Address all correspondence to:  
CINEMAGIC—Filmmakers' Forum, c/o O'Quinn Studios, Inc., 475 Park Ave. So., New York, NY 10016

Due to the enormous volume of mail received, the editor regrets individual replies are impossible.

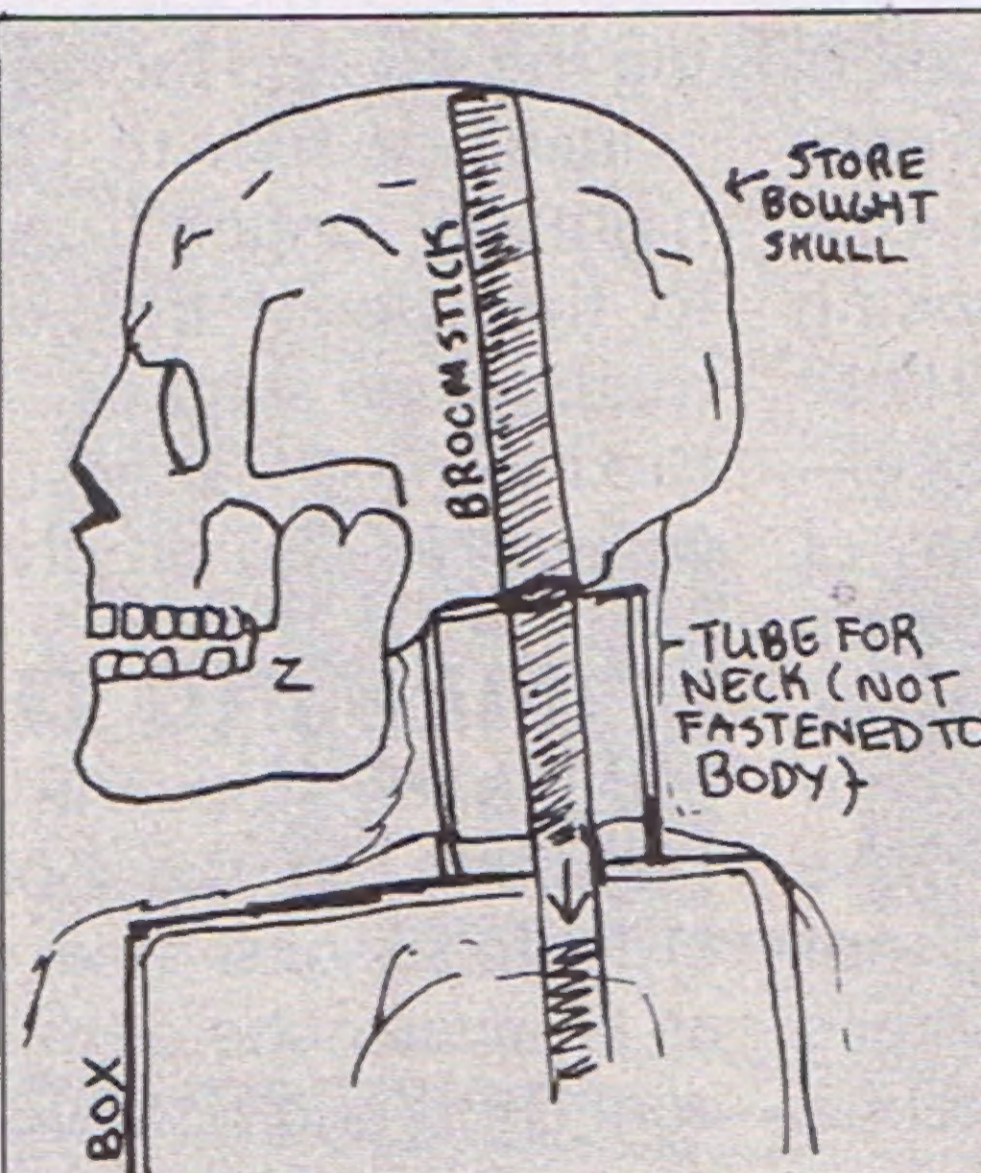

## Paper Mache Zombie

... Discovering that latex was too expensive for my sparse wallet, I improvised by using paper mache to make a zombie for my latest film. I bought a skull model in a store for \$8.00, sawed off a broom handle and stuck it into the hole in the bottom of the skull. The broom handle should be at least three feet long. Next, I took a box and cut it in half, lengthwise, so that it was about body width. I reglued a piece of cardboard onto the box so that it was four-sided. Looking down at the top of the box, I punched a hole (the diameter of the broom-

stick) in the top center and inserted the broomstick "neck." Next, I took a stack of old newspapers and added shape to the body, putting on ribs, a cardboard tube for the neck and further detailing the skull so that it looked like it was rotting. For a final coating, I covered the zombie with paper toweling, which is much thinner than newspapers and easier to work with. When the paper mache was dry after a few days, I took an old shirt (pajama tops work great) and put it on the body, making it look old and tattered. This completed the top half of the zombie's body, except for painting. Both the body and the clothes should be painted the same color—brown or greyish—using flat paint. Further details can be added by having glowing lights for eyes, a movable mouth, or by sticking live earthworms into the empty eye sockets for disgusting closeups. The results I've achieved with these techniques are very satisfying, the best part is that it only cost ten dollars!

**Kevin Lindenmuth**  
36038 Crompton Circle  
Farmington Hills, MI  
48018

# CINEMAGIC BACK ISSUES

**#1**—Backwinding Super-8 Film. Foreground Miniature Technique. Aerial Brace Construction



**#2**—Spaceship Model-making. Blood Makeup. Smoke Generator. Light Beam Effects. Making an SF Logo



**#3**—Robot Construction. Developing an Animation Style. Fluid Art Animation. Electronic Special Effects

**#4**—Aerial Image Optical Printer Construction. Wire Armatures. A-B Rolling. More Electronic Special Effects. Fog and Mist Effects

**#5**—Aerial Image Optical Printer Usage. Wide-screen Super-8. Slit Scan Effects. Gleaming Eyes for Stop Motion Models

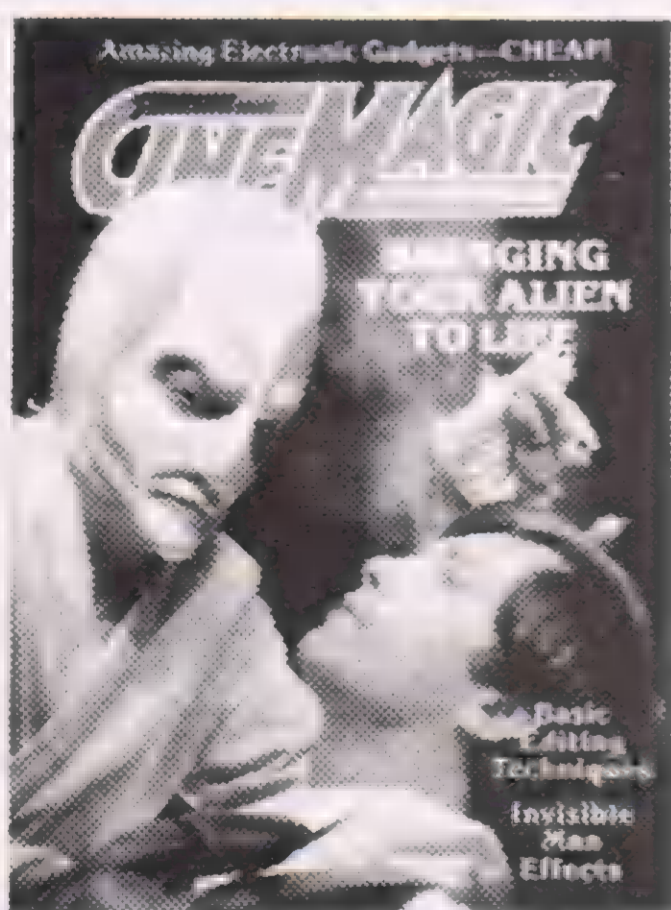

**#6**—Amazing Electronic Gadgets—Cheap! Bring Your Alien to Life—Latex Masks. Basic Editing Techniques. Invisible Man Effects

**#7**—Basic Cartoon Animation. Claymation. Kaleidoscope Effects. Profile Santostephano

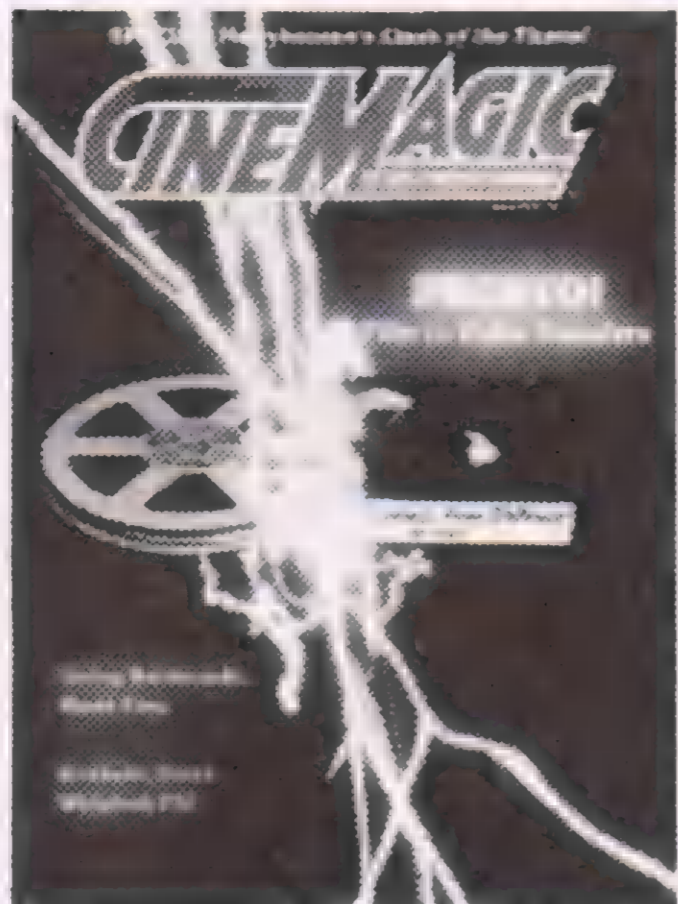

**#8**—Video Tape Transfers. Reverse Filming Effects. Lab Services: Profile Vitous and Antonucci. Clash of the Titans Preview

**#9**—Animating Pogo. Lithographic Tinting Effects. Sets on a Shoestring. Profile The Langley Punks

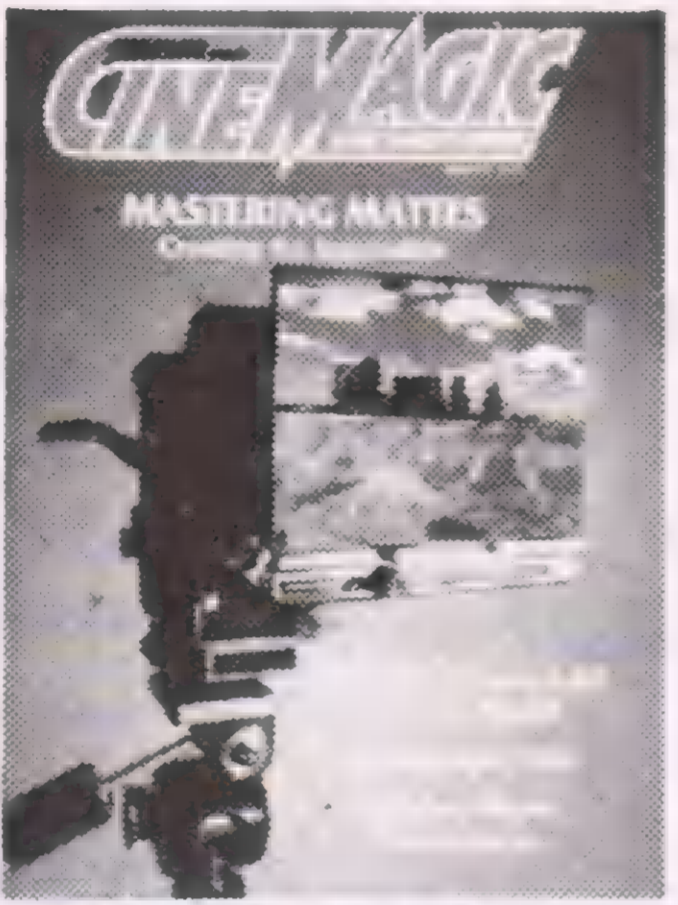

**#10**—Mastering Mattes. Zero Budget Sets. CINEMAGIC/SVA Awards Night. Building a Super Soundtrack. Pen Set Ball-and-Socket Armatures

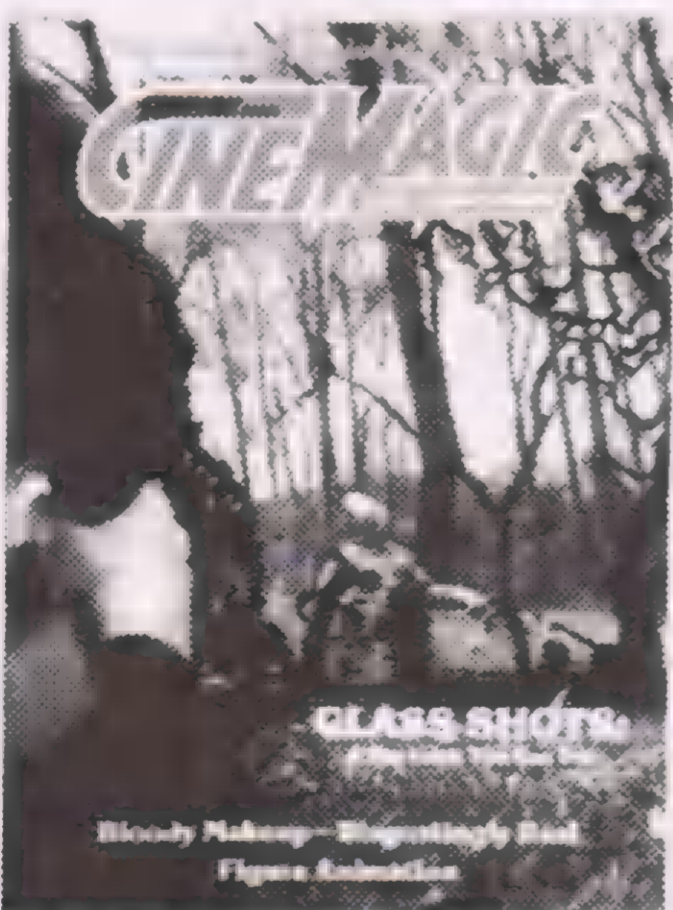

**#11**—Glass Shots. Miniature Explosions. Figure Animation. Bloody Hair Hunks. Profile Koch and Lohr

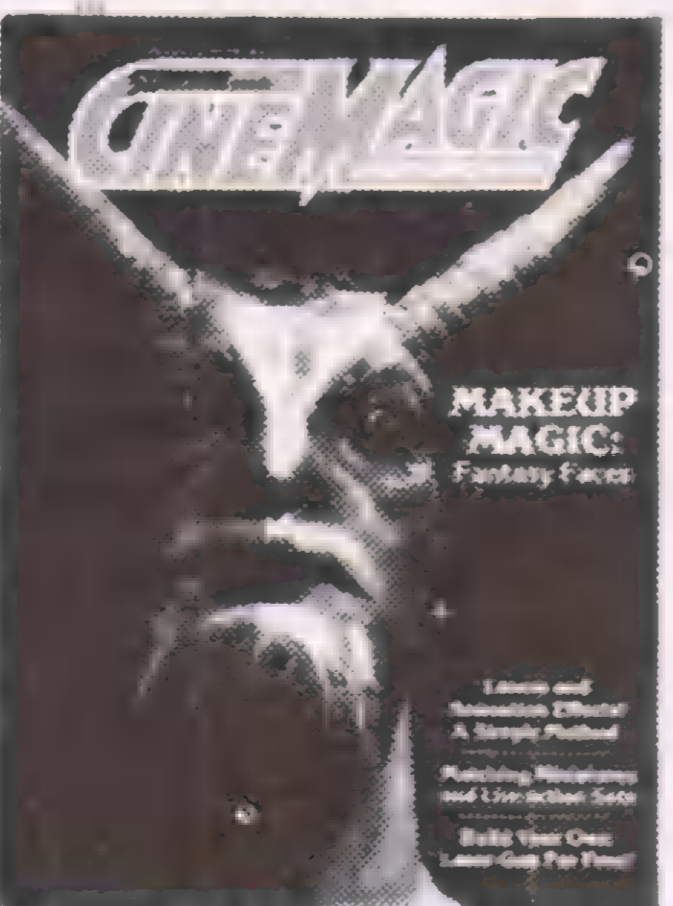

**#12**—Makeup Magic—Latex Appliances; Rotoscoping. Zero Budget Ray Gun. Profile Barnes and Gilger.

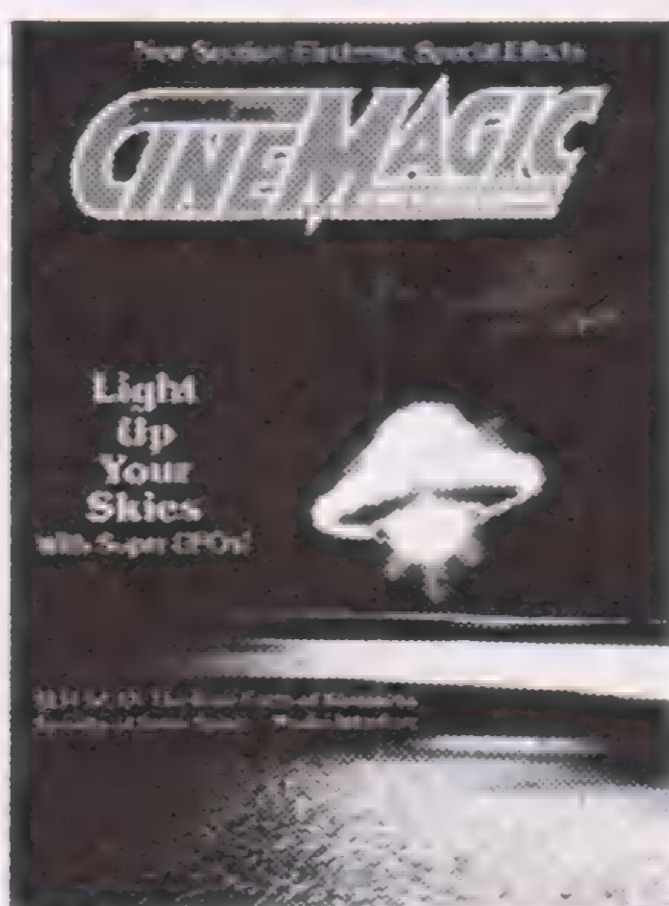

**#13**—Slit Scan: Creating UFO "Lightships"; Model Interiors; More Electronic Special Effects; The Saturn Machine; Profile: Borucki.



**#14**—Storyboarding: Sound Effects Generator; Miniature Devastated Cities. Charles Jones' 16mm Space Epic; Profile: Jerry Paris.

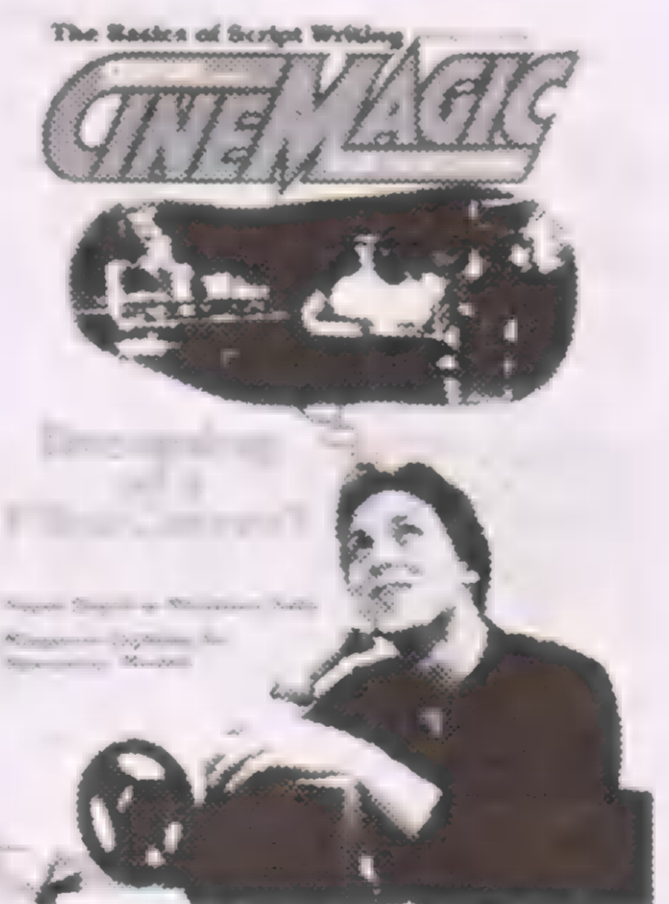

**#15**—Script Writing. Miniature Lighting; Electronic Special Effects; Careers: Super Depth in Dioramas. Profile: Ralph Miller.

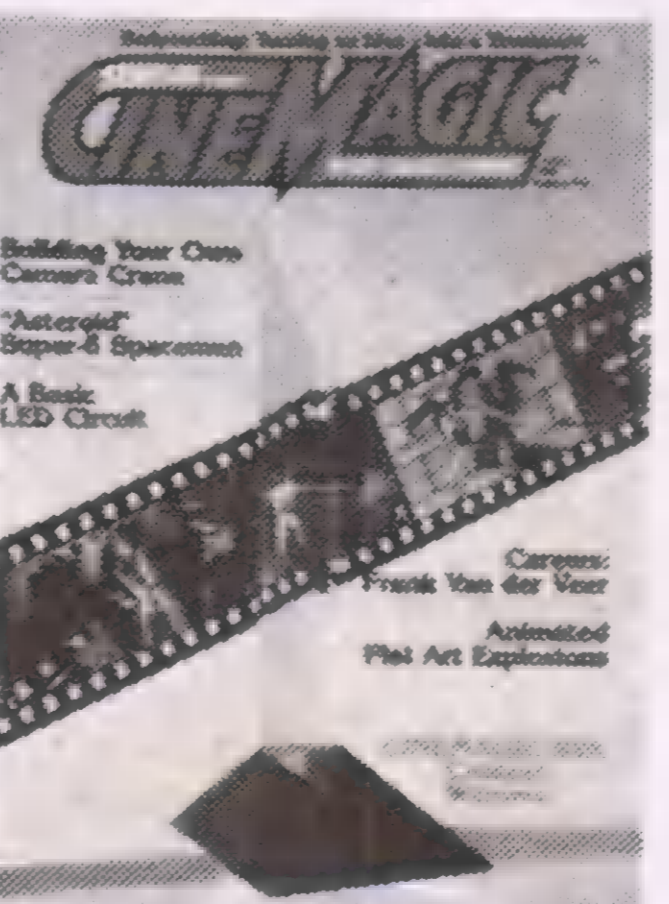

**#16**—Scriptwriting. Part 2: Electronic Special Effects. LED Circuits; Flat Art Explosions; Careers: Frank Van der Veer; Build Your Own Camera Crane; Profile: Paady and Rudow.

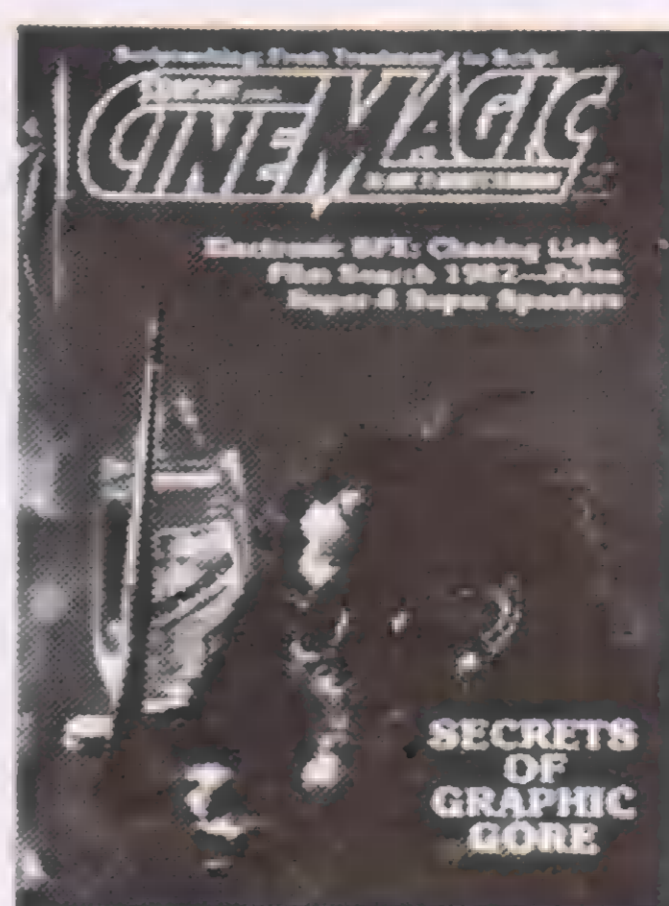

**#17**—Scriptwriting. Part 3: Production managing Low Budget; Electronic Special Effects; CINEMAGIC/SVA Contest Rules; Secrets of Graphic Gore; Profile: Callaghan and Griffith.

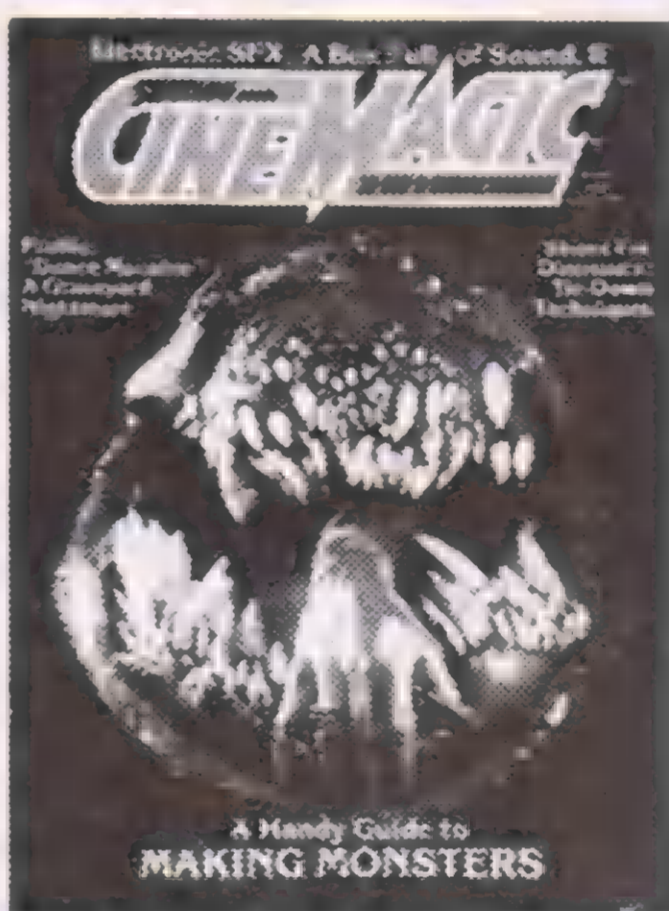

**#18**—Making Monsters; Tie-Downs for Animation Models; Accessories for Filmmakers; Electronic Special Effects; Profile: Al Magliochetti.

**#19**—CINEMAGIC/SVA Awards Night; Build your own Cobweb Spinner; High School Werewolf; Careers: Georges Melies; Electronic Special Effects; Front Light/Back Light Animation Technique.



**#20**—Articulated Full Head Masks; Dream Screen; Precision Ball-and-Socket Armature Parts; Electronic Special Effects; Profile: Joey Ahlbum.



**#21**—Custom Spaceships; Electronic SPFX: DC Strobe; Careers; Robert Short; Foam Rubber Build-up Method; Creating a Monster; Profile: Deborah Von Moser.

CINEMAGIC c/o O'Quinn Studios, Inc.  
475 Park Ave. South, New York, NY 10016

Add postage and handling to your order: \$0.80 for one issue; \$1.14 for two; \$1.60 for three; \$2.00 for four; \$2.40 for five; \$2.70 for six; seven eight.

- Check issues desired.
- |                                     |                                     |
|-------------------------------------|-------------------------------------|
| <input type="checkbox"/> #1—\$3.00  | <input type="checkbox"/> #11—\$3.00 |
| <input type="checkbox"/> #2—\$3.00  | <input type="checkbox"/> #12—\$3.00 |
| <input type="checkbox"/> #3—\$3.00  | <input type="checkbox"/> #13—\$3.00 |
| <input type="checkbox"/> #4—\$3.00  | <input type="checkbox"/> #14—\$3.00 |
| <input type="checkbox"/> #5—\$3.00  | <input type="checkbox"/> #15—\$3.00 |
| <input type="checkbox"/> #6—\$3.00  | <input type="checkbox"/> #16—\$3.00 |
| <input type="checkbox"/> #7—\$3.00  | <input type="checkbox"/> #17—\$3.00 |
| <input type="checkbox"/> #8—\$3.00  | <input type="checkbox"/> #18—\$3.00 |
| <input type="checkbox"/> #9—\$3.00  | <input type="checkbox"/> #19—\$3.00 |
| <input type="checkbox"/> #10—\$3.00 | <input type="checkbox"/> #20—\$3.00 |
|                                     | <input type="checkbox"/> #21—\$3.00 |

NAME \_\_\_\_\_

ADDRESS \_\_\_\_\_

CITY \_\_\_\_\_

STATE \_\_\_\_\_

ZIP \_\_\_\_\_

# Electronic SPECIAL FX

## Super Flash

Build this accessory to the sync strobe unit described in issue number twenty.

By CHRIS E. STEVENS

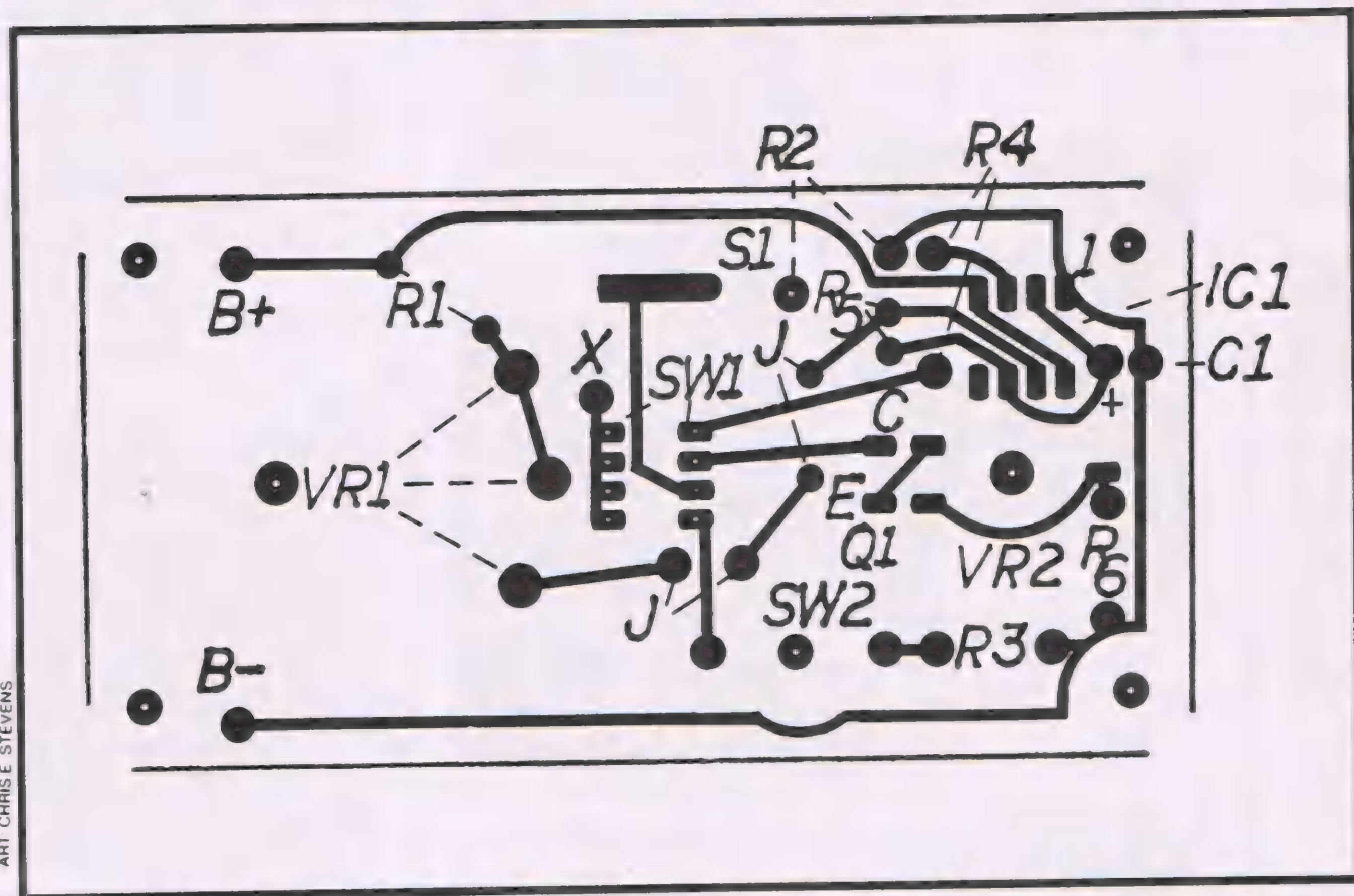

PC board layout, bottom view. Shown actual size. Use this as a pattern when etching your PC board. The unit is connected by an extension cable to the main sync strobe unit described in issue #20.

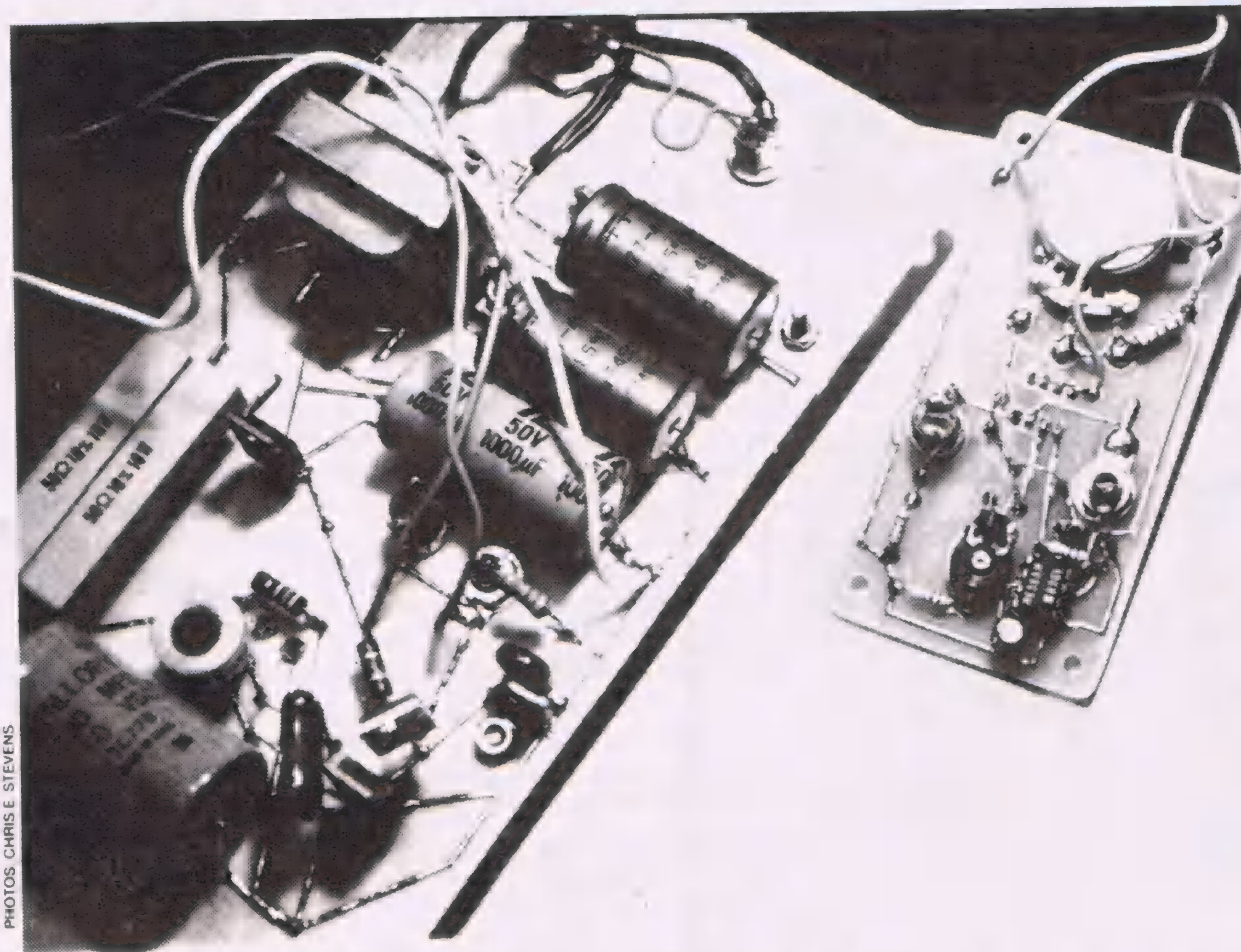

The main strobe unit that was described in issue #20 is on the left in this photo. The accessory unit that is this issue's project is on the right. The accessory adds several functions to the original unit.

It's almost four in the morning. The PC board layout is done. The schematic drawings and the prototype are done. It's time to photograph the project for this issue's article. I set up the lights, load the camera and set the unit up. I check the lighting and everything looks ok so far. Oops, the resin from the solder on the PC board is causing some glare. No problem, I think, until I grab some "stripper" made for removing the excess flux. Just a quick spray and I'll be ready to shoot. The aerosol works perfectly, shooting out a strong spray of solvent. The PC board comes clean on the circuit side. Then I turn it over and guess what? Now I've got a problem. The results of hours of work are ruined, as the carefully lettered and painted front of the project slowly melts into oblivion. A few choice four-letter expletives later, I decided to show you the results, so that you might know that old man "Murphy" still lives, and that life is not necessarily made better through chemicals.

In any case, I hope that by the time that you finish this article, you'll have a good idea of what this melted mess of goo is supposed to be. In addition, I hope that you'll take a lesson from this, which is all too obvious. However, the circuit side of the project is still ok, and except for the cosmetics, it still works quite well. This is one project that I'm afraid I won't want to show to everyone until I rebuild it. In the meantime, it's in a box hidden from my view. In essence, I wanted to share this experience with you, so you know that so-called "professionals" have their bad days (or weeks) too. After all, we are only human, and it's ok for you to get a chuckle out of this.

Getting on to the more serious side of this project, in CINEMAGIC #20, we did a project for a strobe unit to be synchronized with a movie camera with an external sync output, or also for a still camera with electronic flash sync. After completing that article, I decided that it would be nice to add some additional capabilities to the unit so that it would be a more versatile tool. This project is the addition that should just about cover all

of your needs. It has a manual trigger, sync input, slave function and also employs a timer for use as a stroboscope with a variable flash rate.

Before the front of the pictured unit melted away, the labels would have indicated the functions. The unit has a four position switch, which allows you to select any one of the combinations. In addition, the unit is connected via an extension cable and takes its power from the main strobe described in CINEMAGIC #20. The original layout of the main strobe unit is shown with the connecting points indicated so that it will be easier to locate the proper connection points. The type of connectors that you choose is left to your discretion. There are only three wires needed for the remote, and you can use either the direct wiring technique, or you can take the time to install sockets and make the extension cords with the matching plugs to any length you like. Just make sure that you follow through with the wiring so that you keep the connections correct. *Usually* the plugs and sockets are numbered on the wiring side, so that you can follow through with little trouble.

Since the trigger transistor in the main strobe unit that drives the SCR is a PNP variety, the output from the remote control unit supplies a *negative* pulse. As a result, everything is referenced to ground. The B+ is used only for the timer IC. Also,

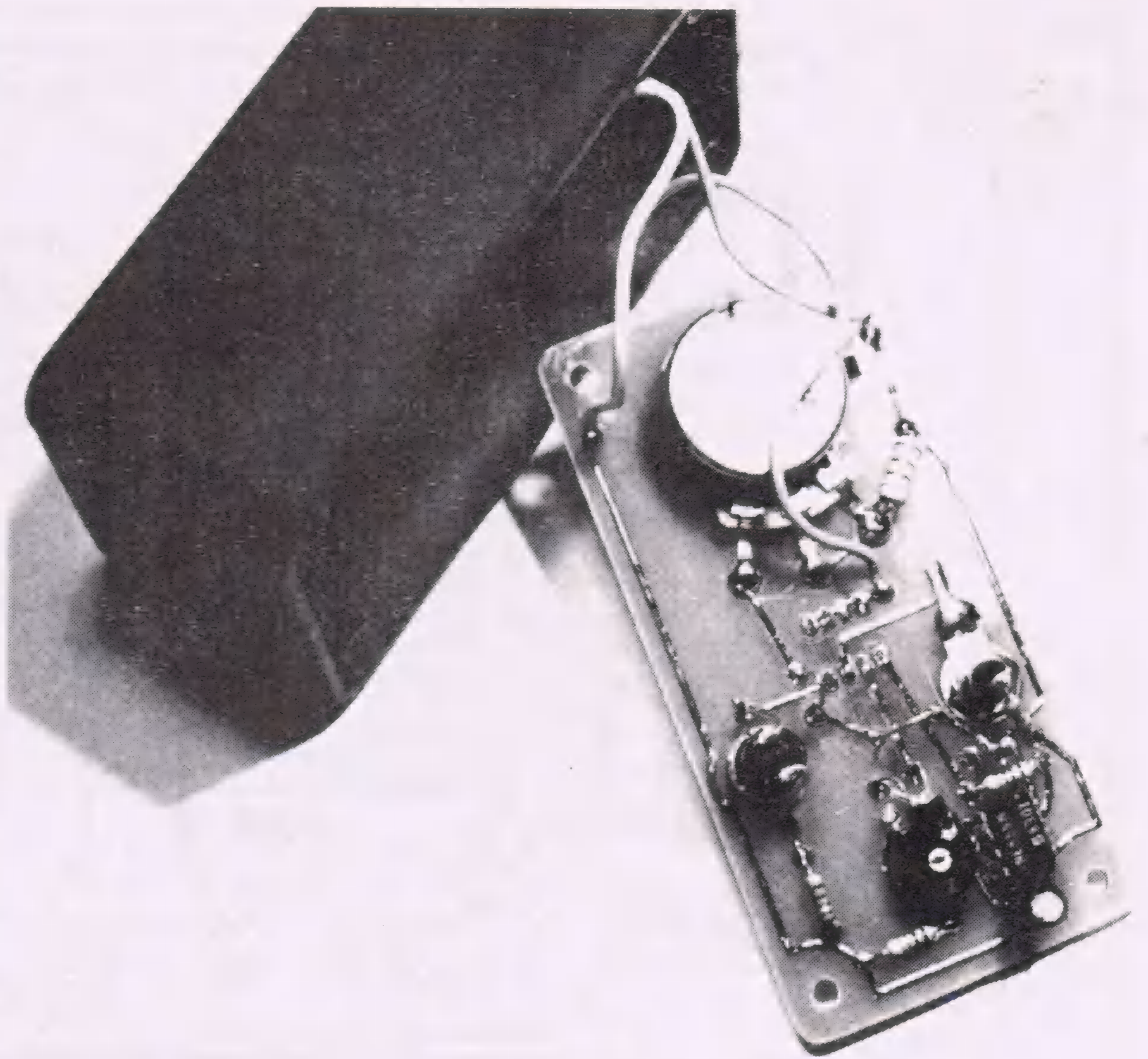

The bottom view of the completed auxiliary control unit is shown prior to mounting in the project box. The auxiliary unit draws its power from the sync strobe unit described in issue #20.

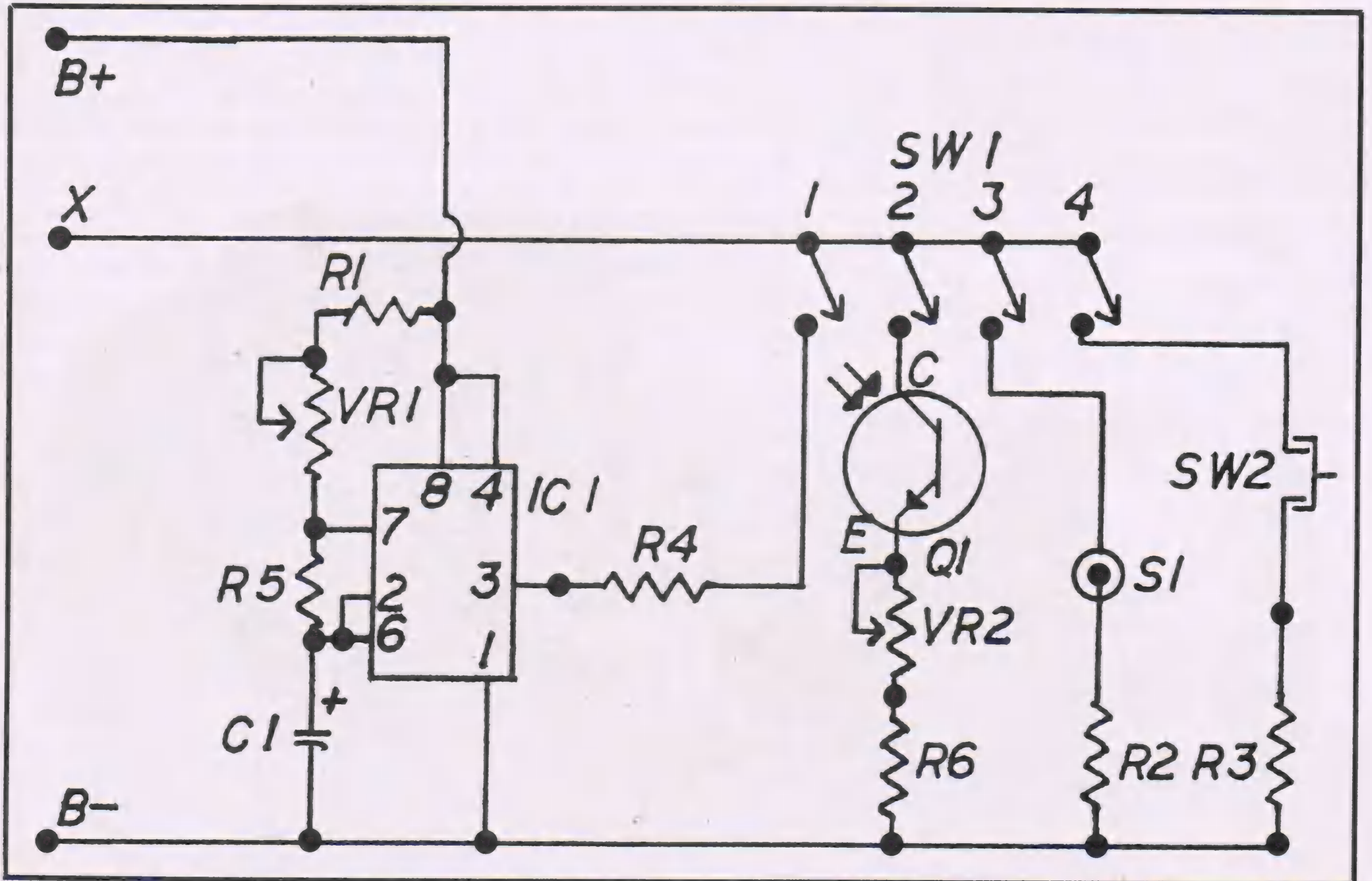

The schematic diagram of the auxiliary control unit that is described in this article is shown here. Switch #1 controls the functions. Position #1 of SW-1 is for the variable strobe function. Position #2 is for the slave function. Position #3 is for the sync input function and position #4 is the manual trigger.

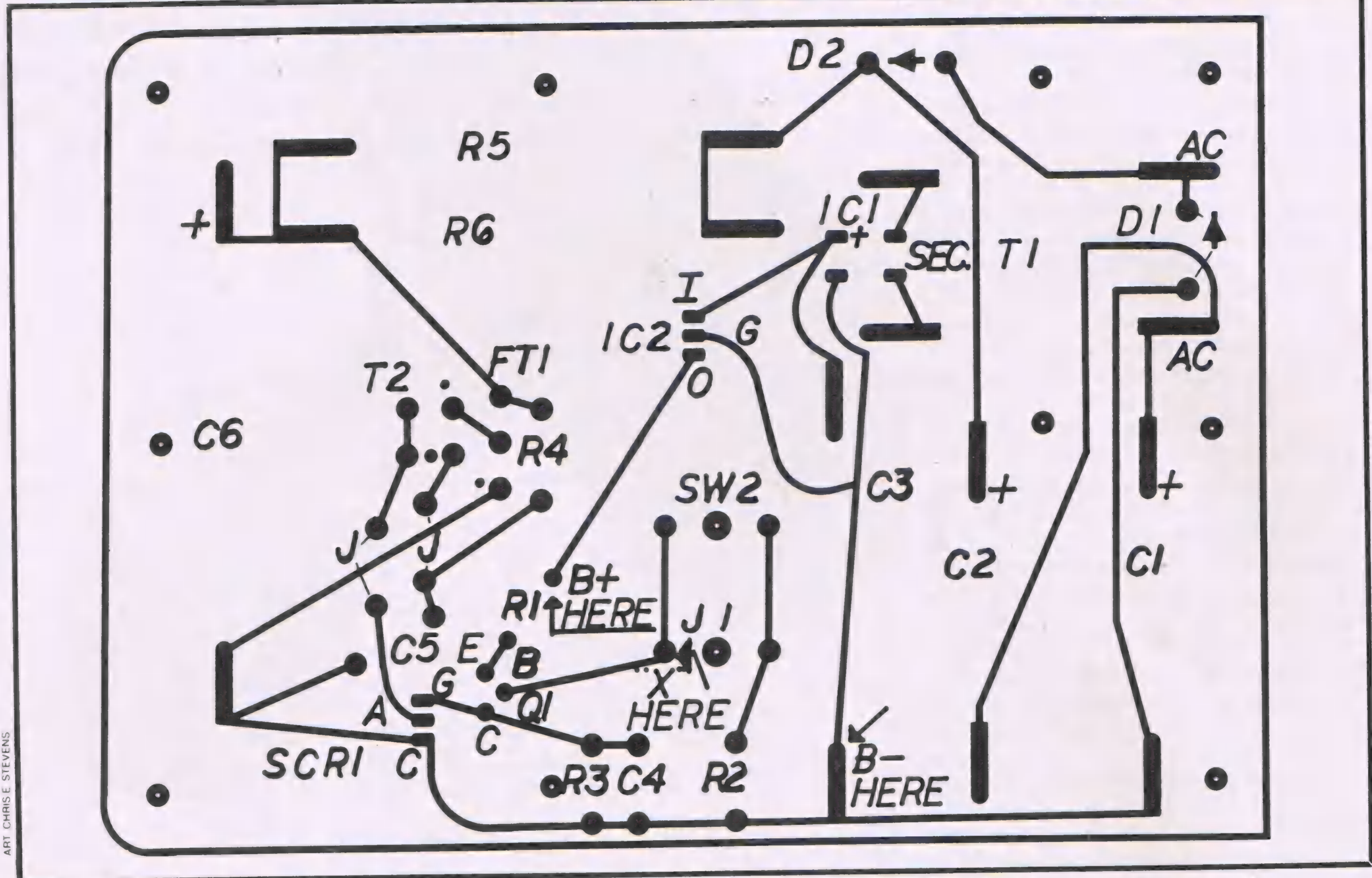

ART. CHRIS E. STEVENS

The PCB layout of the sync strobe unit described in CINEMAGIC #20, with B+, B- and "X" locations marked for ease in locating the connecting points.

if you are building the strobe unit described in CINEMAGIC #20, be sure to check the leftover parts for what you need. The pushbutton switch is the same as the one in the main unit as well as the shielded phono plug. You might even

have enough copper clad board left over from one of your previous projects to complete this one.

Here are some construction hints so that you will have success the first time. First of all, *do not use flux remover* (heh,

heh) and make sure that the PC board you choose is totally opaque. The reason that an opaque PC board is necessary is because Q1, is a photo transistor and is sensitive to light. The PC board that I had acquired was semi-transparent, and had

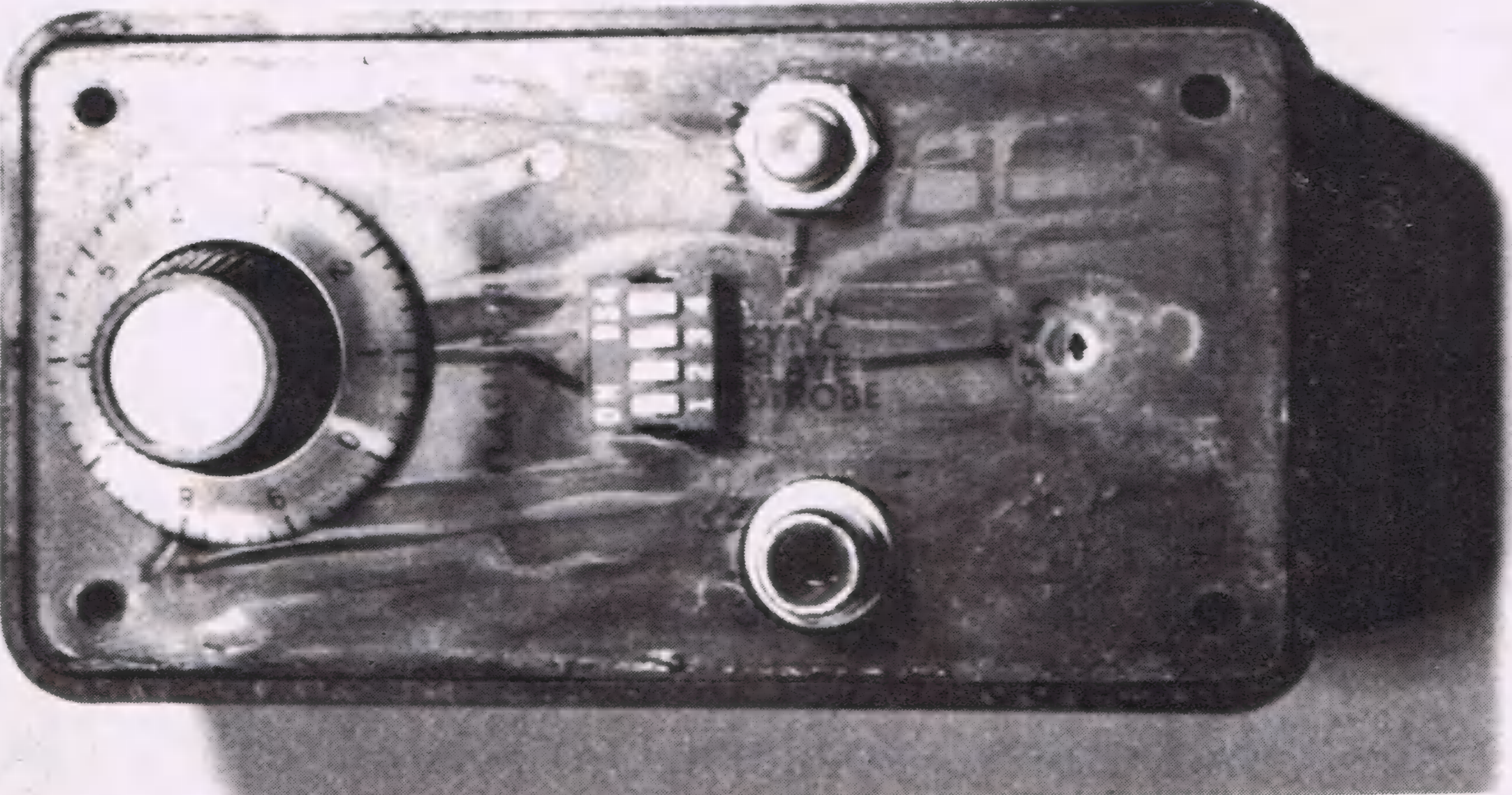

PHOTOS CHRIS E. STEVENS

The completed auxiliary control unit mounted in a project box. If the lettering on the front wasn't ruined by the unfortunate flux remover incident, you could read the functions. The dial on the left is for changing the flash rate of the variable strobe function. I hope yours looks better than mine.

# PARTS LIST

VR-1	1 megohm variable resistor	271-211
VR-2	10 k-ohm variable resistor	217-335
R-1	680 ohm 1/2 watt resistor	271-021
R2,3,4	2.2 k-ohm 1/4 watt resistor	271-1325
R5,6	1 k-ohm 1/4 watt resistor	271-1321
SW 1	4 position mind-dip switch	275-1304A
SW-2	SPST pushbutton switch N.O.	275-1547
S-1	Shielded phone jack	274-346
C-1	10 uf at 35 VDC capacitor	272-1025
IC-1	555 Timer IC	276-1723
Q-1	Photo transistor FPT-100 type	276-130

Misc. 3x6-inch PC board (276-1586); Project Box (270-231); Connectors (see text); Transfers (276-1577); Wire (see text); Etchant (276-1535); Knob - speed control (your choice).

As a convenience, the catalog numbers listed are RADIO SHACK numbers, except any marked with an asterisk.\* For those parts, see the text for more information.

to be painted. Drill *only* the dots with a white center mark. These are the mounting holes for VR-1, VR-2; SW-1, 2 and also for the phono jack. The solid dots are solder pads. Take a close look at the photograph, especially for Q1. If you'll notice, it's bent at a 90 degree angle over VR2. Be sure to measure the location of the phototransistor and then drill about a 3/8-inch hole in the end of the box so that the transistor can "see" through the end. This will allow the slave portion to work. In addition, the reason that the board layout doesn't have the corners inked in, is because the lids on the project boxes vary somewhat, and it should be used as a template for cutting the circuit board. This will give you a more accurate fit when the PC board becomes the new front plate.

After you have everything completed *double check your wiring*. This is important. Be sure that you have the polarities and the connections correct before you apply power. Turn all the function switches "off" and test the unit one step at a time. Test the manual trigger first, then the sync, by bridging the connector outer shield to the center pin. The next step is to test the slave. Turn the sensitivity control (VR2) all the way down and cover the hole in the end of the box with your hand. Point the box at a bright light and then remove your hand. It should flash. If not, check Q1 to make sure that it is properly installed. As an added note, Q1 has three leads. Before installing the transistor, cut the *base* lead off, leaving only the collector and emitter leads. The collector lead goes to the pad that leads to the function switch side, and the emitter goes to VR2.

The final test is the strobe position. Turn the speed control 3/4 of the way up, and turn on the strobe function switch. It should strobe. If not, check for wiring errors. In the event that you have miscon-

nected the B plus and minus leads, the unit will not function. If this is the case you will run the risk of burning out parts in the remote unit, especially the timer IC. If the other functions work properly and the strobe is the only thing not functioning as it should, also check the polarity of the electrolytic capacitor. If the polarity is incorrect it will stop the timer from working. Other problems can arise from not having the four position switch completely on, in the mode you select. In addition, having more than one switch on at a time will cause the unit to fail to fire. This is especially true when the slave and strobe are on at the same time. Only one function should be used at a time.

Here's hoping your project comes out better-looking than mine. Coming up in the next issue will be an elapsed frame counter for movie use, with a 9,999 frame capacity for more accurate backwinding and better special effects. After that, an intervalometer for time-lapse photography. You might expect both of these projects to have the abilities to work in conjunction with each other. In the past, I've had a lot of requests for the Cylon speech duplicator. Unfortunately, I've been unable to gain enough information with which to work. Be patient. I haven't given up the idea yet. 

## Let's Hear From You!

I'd really like to hear your suggestions for future electronic special effects projects, and also how your projects turn out. If I can, I'll try to answer any questions you might have about how some of the special effects are accomplished. If you wish a personal reply, please enclose a S.A.S.E. and allow some time for your response, while the mail is forwarded. Address all correspondence to: Chris Stevens, c/o Cinemagic Magazine, 475 Park Avenue South, New York, New York 10016.

## SUBSCRIBER SERVICES

Missing copies? Moving? Renewals? Receiving duplicate issues? Questions about your subscription? Write directly to:

### CINEMAGIC

Subscriber Services,  
P.O. Box 142  
Mt. Morris,  
IL 61054

### NEW SUBSCRIBERS ONLY:

Do not send money and order to the above address. See subscription ad elsewhere in this issue.

Label Goes Here

Subscription inquiries addressed to the editorial offices will only delay your request.

NAME \_\_\_\_\_

ADDRESS \_\_\_\_\_

CITY \_\_\_\_\_ STATE \_\_\_\_\_ ZIP \_\_\_\_\_

## SPECIAL EFFECTS TECHNICIANS WANTED FOR MOTION PICTURE WORK

Filmmakers, Special Effects Technicians, Sound Effects Technicians

If you have any experience in any of the listed categories or related fields of filmmaking then we are very interested in a sample of your work for screening to determine your eligibility for hiring you for your services in Science Fiction motion pictures that we are developing for theatrical release. Whether you are professional or amateur-professional we request that you forward a videotape (VHS), 16mm or Super-8mm copy of your special effects work to us as soon as possible.

Stop Motion Animators/Computer Graphics Artists/Computer Programmers/Scientists/Sculptors/Model-makers/Spaceship Designers/Engineers/Artists: Space/Comic Book/Matte/Matte Photographers/Costume Designers/Video Artists/Effects/Robot Builders/Engineers/Industrial Designers/Lighting Effects/Sound Effects/Exotic Monster Designs

V.E.D. Corp.  
25 West 45th Street  
Suite #1401, Dept. SPFX  
New York, N.Y. 10036  
(212) 730-1188

## Producers'

# BULLETIN BOARD

Contact filmmakers in your area! See names below, also Filmmakers' Forum, page 10.

Please forward announcements of film projects in current production or near completion to CINEMAGIC, c/o O'Quinn Studios, Inc., 475 Park Avenue South, New York, NY 10016. Please include a photograph of some phase of the production if possible.

**Fantasy.** When a mortal fantasy being relaxes in a peaceful scenario instead of venturing forth into the world, the God becomes angry and disintegrates him on the spot. The entire setting changes, however, for the destroyed character is only an imagined personage in the mind of a disappointed fantasy game player and the God is but a figment in the mind of a game referee who, after the lazy player protests too much, gets carried away with fantastic intentions and astonishingly disintegrates him right on the spot from the opposite side of the gaming table. Producer/Director: Brian Hughes. Production Assistants: Roger Merritt and Mike Miarecki. Cast: Mark Riegner, John Stipe and Andy Pelletier. FX include: fades, backlit silhouette titles, miniature sets and explosions, cloud tank effects, pyrotechnics, plus original music and sound effects. Super-8, color, sound. Running time: approximately 5 minutes. (Brian Hughes, 3405 Belmont Coeur d'Alene, ID 83814.)



**The Fear.** Four teenagers are trapped in a house with no escape. Who will survive? Producer: Ale Turner. Directors: Ale Turner and David Cavalier. Writer: David Cavalier. (Digital Films, c/o David Cavalier, 330 E. 33rd St., New York, NY 10016.)

**Licensed to Kill.** A James Bond spy thriller. Bond has to stop a group of terrorists who are bombing important buildings and killing British Secret Service agents. 007 travels to New York City to stop them. Producer/Director: Steve Sessions. Cast: Steve Sessions, Jim McLoughlin, Frank Gadaleta and John Turiano. FX include: fight scenes, miniatures, explosions, electrocutions, gun shot wounds and more. Some scenes filmed in New York City. (Steve Sessions, 20 Crescent Ave., Rye, NY 10580.)

**The Class Assignment.** A high school student discovers a meteorite and brings it to school for a science project. A creature is spawned from the meteorite and escapes to the building's suspended ceiling. From there it lives, grows and terrorizes the unsuspecting school. The story is told in flashbacks from a psychiatrist's office and is styled along the lines of the twilight zone genre. Producer: Triumvirate Productions. Director: John Benson. Writer: Jeff Shumpert. Cast: Gary Thacker, Lori McDaniel, Chris Curron and Tony Harrison. FX include: a 7 foot tall creature formed out of polyeurathane, a smaller version of the creature in embryonic form, blood effects and fog effects, original music and sound effects and graphics. Super-8, color, sound. Running time: 9 minutes, 38 seconds. (Triumvirate Productions, c/o John Benson, P.O. Box 149, Buford, GA 30518.)

**It Still Kills.** A hideous living cadaver terrorizes a city. Producer/Director/Writer/FX: John Helton. FX include: double exposures, mattes, fog effects, blood and gore makeup, rubber appliances and pyrotechnics. Super-8, color, sound. Running time 20 minutes. (Helton Pictures Productions, c/o John A. Helton, 1911 Southmore #707, Pasadena, TX 77502.)

**The Undead.** A feature film in which the dead return to life by a chemical released by a refinery. Producer/Director/Writer/FX: John A. Helton. FX include: double exposures, mattes, fog effects, blood and gore makeup, rubber appliances and pyrotechnics. Super-8, color, sound. Running time: 90 minutes. (Helton Pictures Productions, c/o John A. Helton, 1911 E. Southmore #707, Pasadena, TX 77502.)

**Eli: The Motion Picture.** Comedy/Horror. A deadly killer, Eli, stalks the drama students on Cottonwood High's stage. Producer: Imagination Unlimited. Director/Editor/Co-cinematographer: Trent Fordham, Writer/Assistant Director/Co-cinematographer: Mike Green. Cast: Dan Vest, John Burger, Cheryl Smith, Patti Olsen, Joe Peterson, Wendy Bowden, Mike Green, Trent Fordham, Maria Edgar and Jana Larsen. Super-8, color, sound. Running time: 5-10 minutes. (Imagination Unlimited, 1045 E. 5600 S., Salt Lake City, UT 84121.)



**The Bursar's Office.** Twilight Zone-like adventure. Seymour Gutflesh, a college transfer student, attempts to register for classes in the nightmarish place men call...The Bursar's Office. Twist ending. Producer: Starwarp Concepts, Ltd. Director/Writer: Steven A. Roman. Cast: Rich Brown, John Loscalzo, Steven Roman and Marty Barron as Rod Serling. Videotape, black-and-white, sound. Running time: 15 minutes. (Steven Roman 50-41 46th St., Woodside, NY 11377.)

**The Death Machine.** A future war between Earth and an alien planet ends when both sides develop a new secret weapon. Producer: AFP Films. Director/Writer: Ian Hill. FX: David Shusdock. Cast: Robert Roper, Bryan Dunn, Ian Hill and David Shusdock. In post-production. Super-8, color, sound. Running time: approximately 18 minutes. (AFP Films, c/o Ian Hill, 20 Field Rd., Cos Cob, CT 06807.)

**3001: A Spaced-Out Odyssey.** What, another Parody? Yes, this time of 2001 and critic's reactions to it. Producer: AFP Films. Director: Ian Hill. Writers: Ian Hill and Robert Roper. Cast: Ian Hill, Roger Ebert, Robert Roper, Dave Wowman, Gene Siskel, Brian Dunn, David Shusdock and Sterling Roper. Special Defects: Ian Hill and David Shusdock. (AFP Films, c/o Ian Hill, 20 Field Rd., Cos Cob, CT 06807.)

**The Hunt.** He is hunting her. Why? Only the last thirty seconds of this film will tell. Producer: United Productions. Director: Mark Schellberg. Story by Jim Cobb. Screenplay by Mark Schellberg and Gordon Erickson. Super-8, color, sound. Running time: 10 minutes. (United Productions, c/o Mark Schellberg, 912 N. 96th #277, Seattle, WA 98103.)

**The Lycanthrope.** When a man's daughter is brutally killed by a werewolf he is determined to get revenge. What he does not know, however, is that the werewolf is his best friend. Producer: Macabre Productions. Director/Writer/Editor: Chris Eilenstine. Cast: Kenneth Paradise, Charlie Dietrich, Kim DeAngelis, Nathan Gams, Ralph Aunkst and Cynthia Dalton. Super-8, color, silent. Running time: 38 minutes. (Chris Eilenstine, 1595 Gravel Rd., Seneca Falls, NY 13148.)



# CineMagic MARKETPLACE

For as little as \$15.00 you can reach all our special effects fans.

**DEADLINE:** CINEMAGIC #23 in our office by Sept. 21st.  
CINEMAGIC #24 in our office by Nov. 23rd.

**BASIC RATE:** \$5.00 per line. Limit—45 characters per line. Minimum three lines. Punctuation, symbols and spaces count as characters. Small display ads—\$40.00 per column inch (camera-ready ONLY!!)

**HEADLINE:** First line only—Word(s) of your choice (underline them) will be printed in **BOLD CAPS**.

**CATEGORY:** PLEASE BE SURE TO INDICATE THE CATEGORY YOU WANT TO BE LISTED UNDER.

**PAYMENT:** Cash, check, or money order must accompany ad order (checks payable to Starlog Press, Inc.)

**MAIL TO:** CINEMAGIC, c/o Starlog Press, Inc.  
475 Park Avenue South  
New York, NY 10016

## MERCHANDISE

**BLUEPRINTS:** Detailed size comparison chart on space going vessels—KLINGON D7, ROMULAN D6, starship Class Space Cruiser and more. Info on weight, crew, power, etc. Send \$3.00 plus \$1.00 for shipping to:

STARLOG MAGAZINE  
475 Park Avenue South, New York, NY 10016

**SPACE SLIDES For FRONT Or REAR PROJECTION.** Imagine beautiful planets, galaxies, nebulas, etc. in your Super-8 films! Set of ten—\$9.95 to: SLIDES, Sooy Lane, Absecon, NJ 08201

## ★ SCRIPT-CITY ★

Film & T.V. Scripts—Largest Selection—  
—Lowest Prices!!! Huge Sci-Fi & Horror  
Collections. Send for **FREE** 22 page  
catalog...Receive **FREE** Introductory offer!  
Script-City, 1765 N. Highland  
#760CM, Hollywood, CA. 90028

THE BUSINESS END OF THE GORN SHIP  
BLUEPRINTS. TWO BIG SHEETS GIVE YOU  
THE INFORMATION YOU NEED TO KNOW ABOUT THIS  
MEAN LEAN MACHINE. \$4.95 POST PAID.....

STARLOG PRESS  
475 Park Avenue South ★ New York, New York ★ 10016

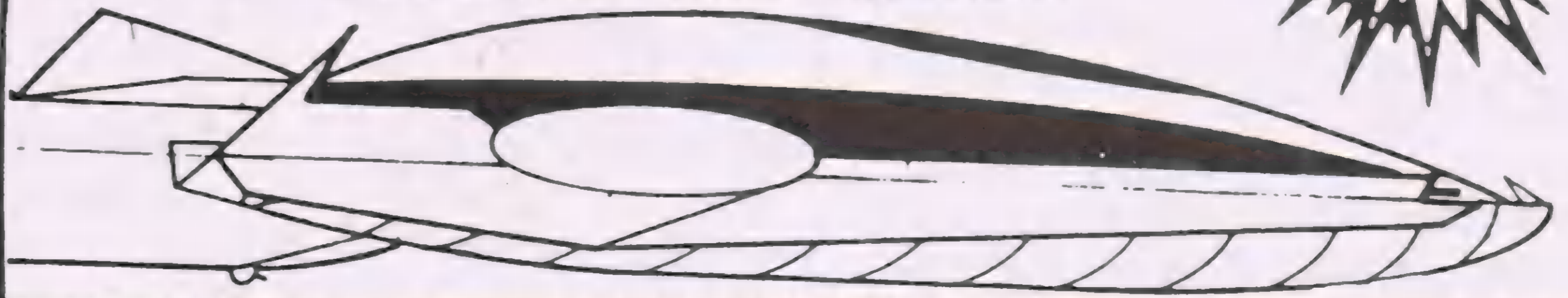

## SERVICES

**Magnetic Sound Striping.** Finest magnetic striping.  
Weberling lamination Super-8/8mm 6¢ per ft., 8¢  
per ft. with balance stripe. Rush Service.  
MAGNESTRIPE, 333 Aycrigg Ave., Passaic, NJ  
07055. (201) 733-4633.

**STOP MOTION MODELS \*** Custom armatures and  
components \* Sculpture and foam casting services.  
Send for information & prices. Ken Brilliant, 24 San-  
ford Rd., East Brunswick, NJ 08816

# The Vertigo Effect

Build this easily-constructed title spinner and throw your audiences for a loop!

By JACK IMES, JR.

**S**pinning titles can really send your audience for a loop! The title spinner described here is a vertical turntable on which titles, photos, or drawings can be attached and tumbled as you film. Made from cardboard, the spinner is easy to build and use. The base is made with an empty film reel and is mounted on one arm of a film editing machine. You can build the title spinner with the simple materials and tools listed below.

#### MATERIALS:

- One 7-inch plastic film reel
- Corrugated cardboard, 8- by 16-inches, double-sided
- Two 3-inch rubber bands
- Two 3/4-inch brass paper fasteners, round head
- Film editor
- Adhesive tape
- Colored construction art paper, 8- by 10-inches

#### TOOLS:

- Art Knife
- Compass
- Pencil

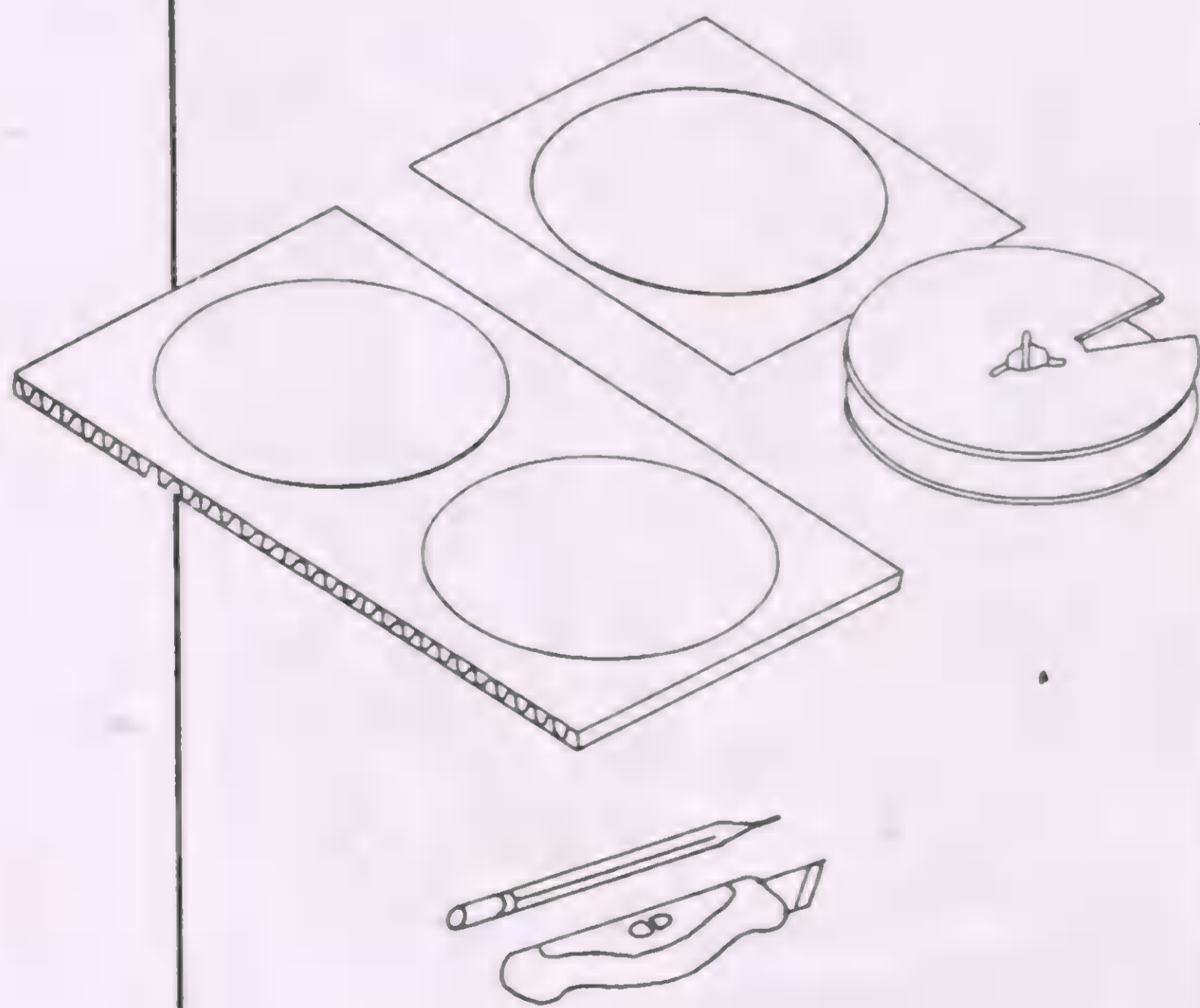

**STEP 1:** Use the empty film reel as a pattern and trace two circles onto the cardboard sheet. You should also trace a circle onto a sheet of art paper to be later used as a title sheet. Use a sharp art knife to cut out all the circles. Be sure to have a firm work surface when cutting the cardboard so the blade will not slip accidentally.

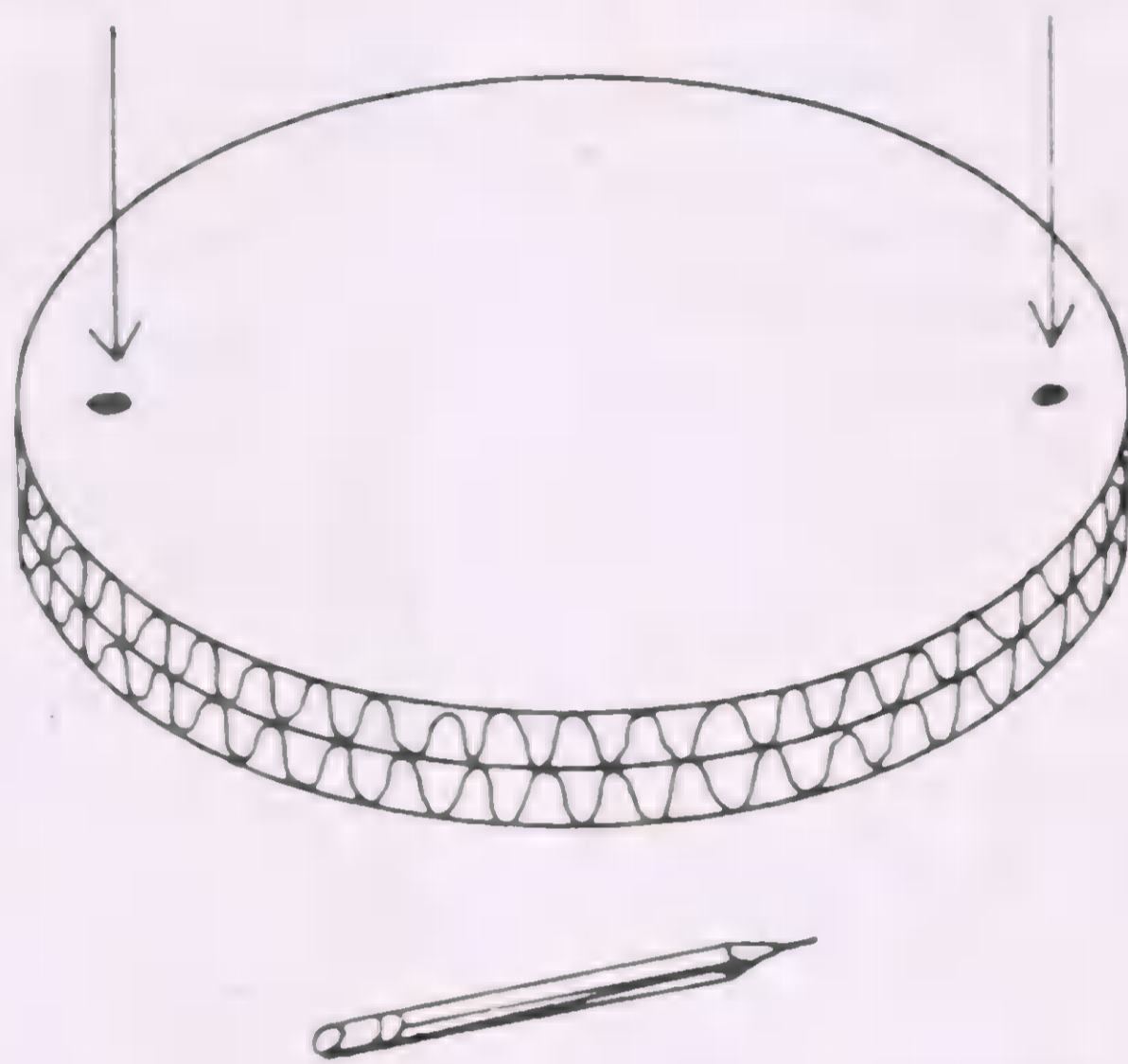

**STEP 2:** Place the two cardboard disks face-to-face on the work table. Use a sharp pencil or a compass point to punch two small fastener guide holes in the disks. The two holes should be positioned at opposite ends of the disk 1/2-inch from the edge. The holes should go completely through both disks.

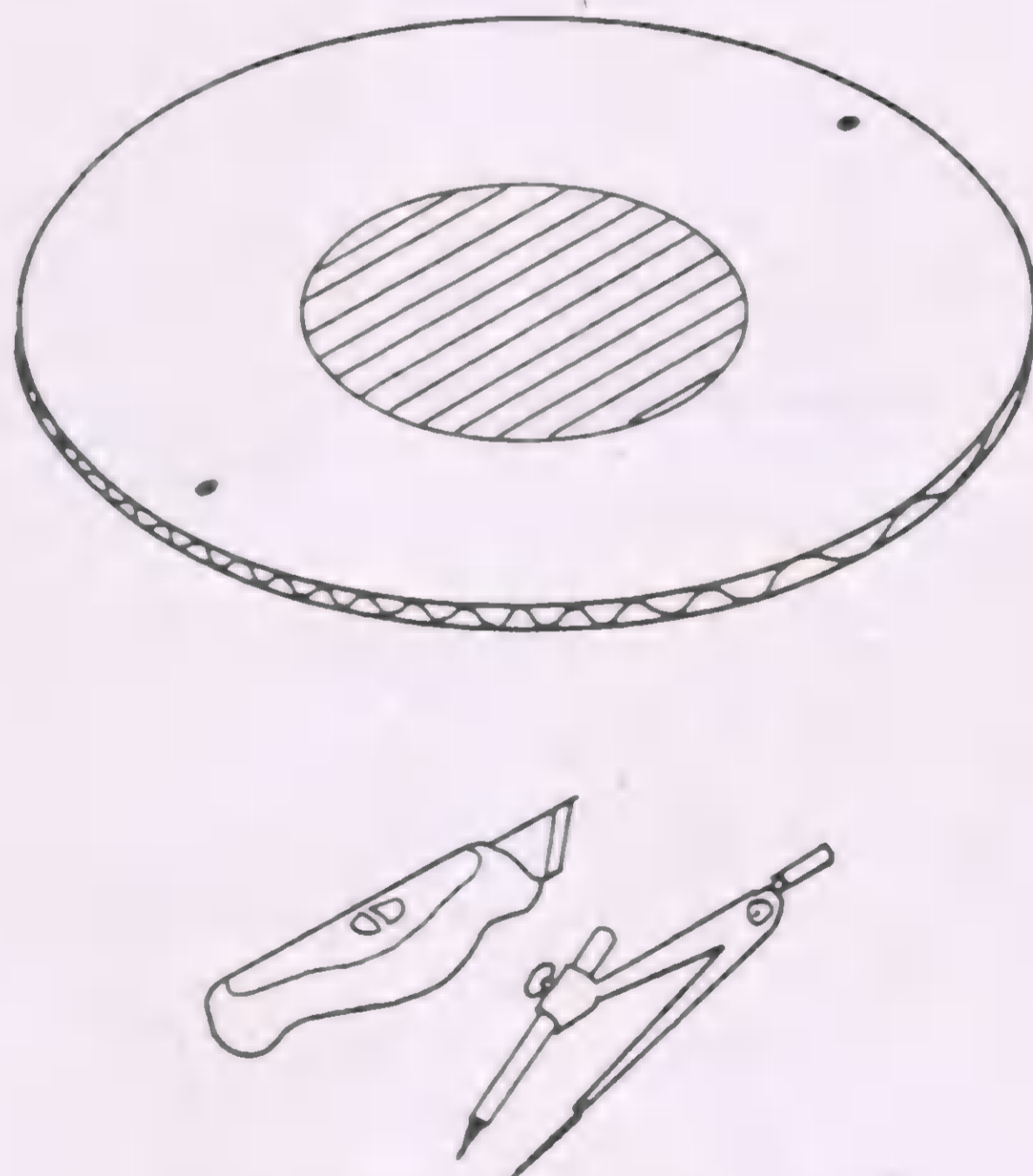

**STEP 3:** Select one cardboard disk and locate the center as closely as possible. Adjust the compass for a radius of 1 1/2 inches. Place the compass point on the estimated center of the disk and draw a circle. Cut out the inner circle section with the art knife and discard it. The remaining ring-shaped disk is to be used and is to be the spacer ring.

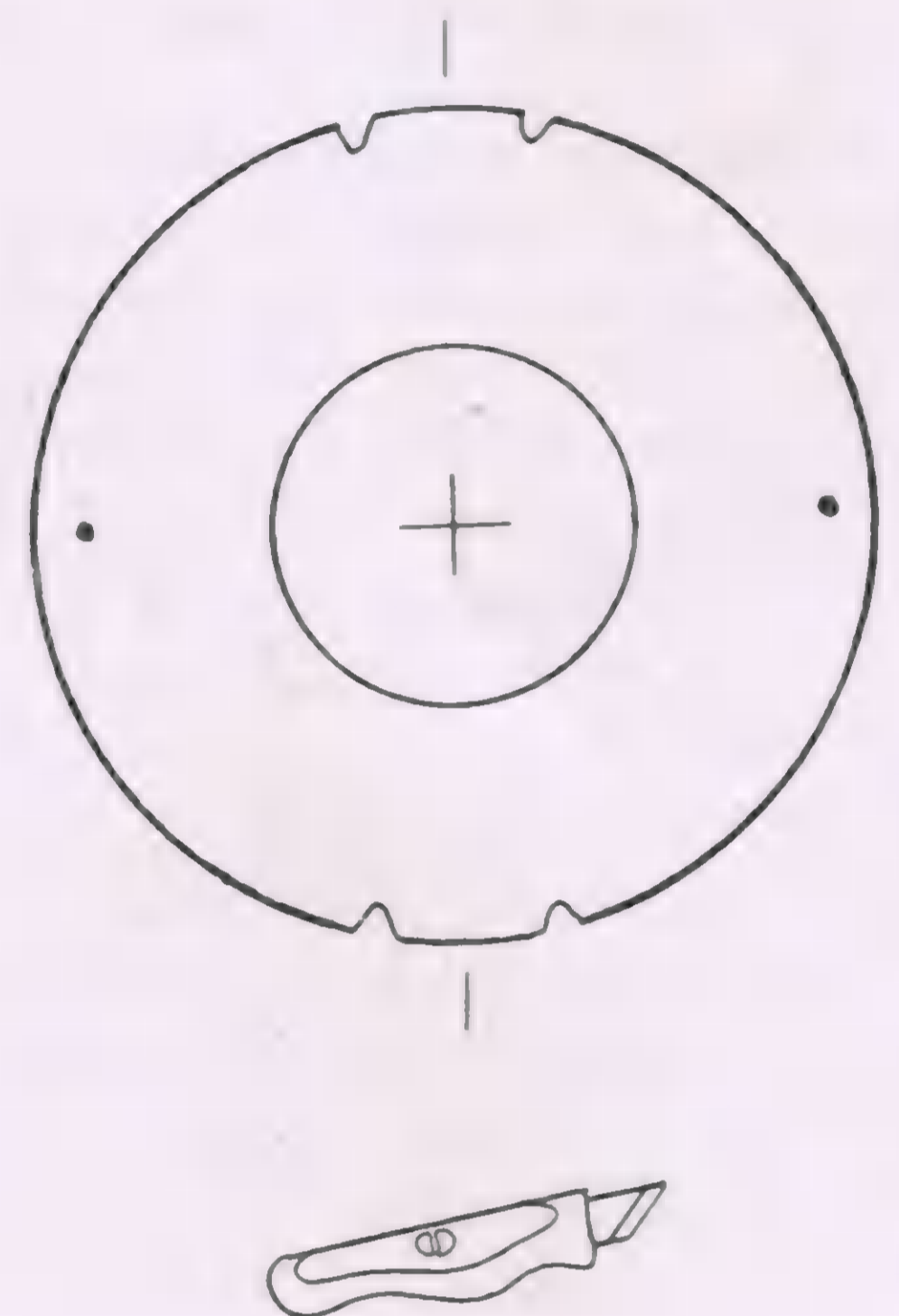

**STEP 4:** Cut two pairs of V-shaped notches on opposite edges of the spacer ring. Each pair of notches will be about 1 1/2 inches apart and 90-degrees from the fastener guide holes.

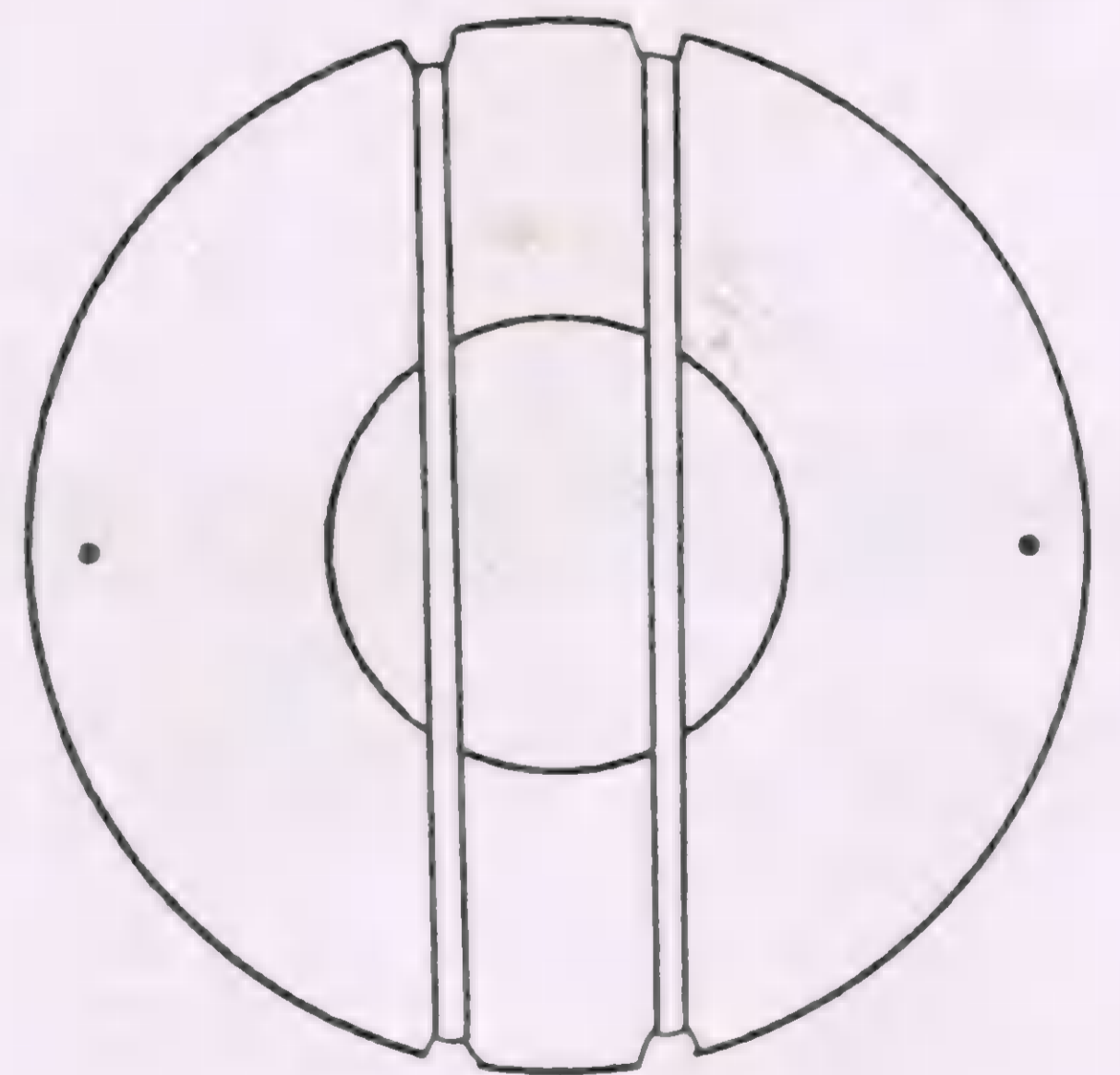

**STEP 5:** Connect the upper and lower notches with two rubber bands.

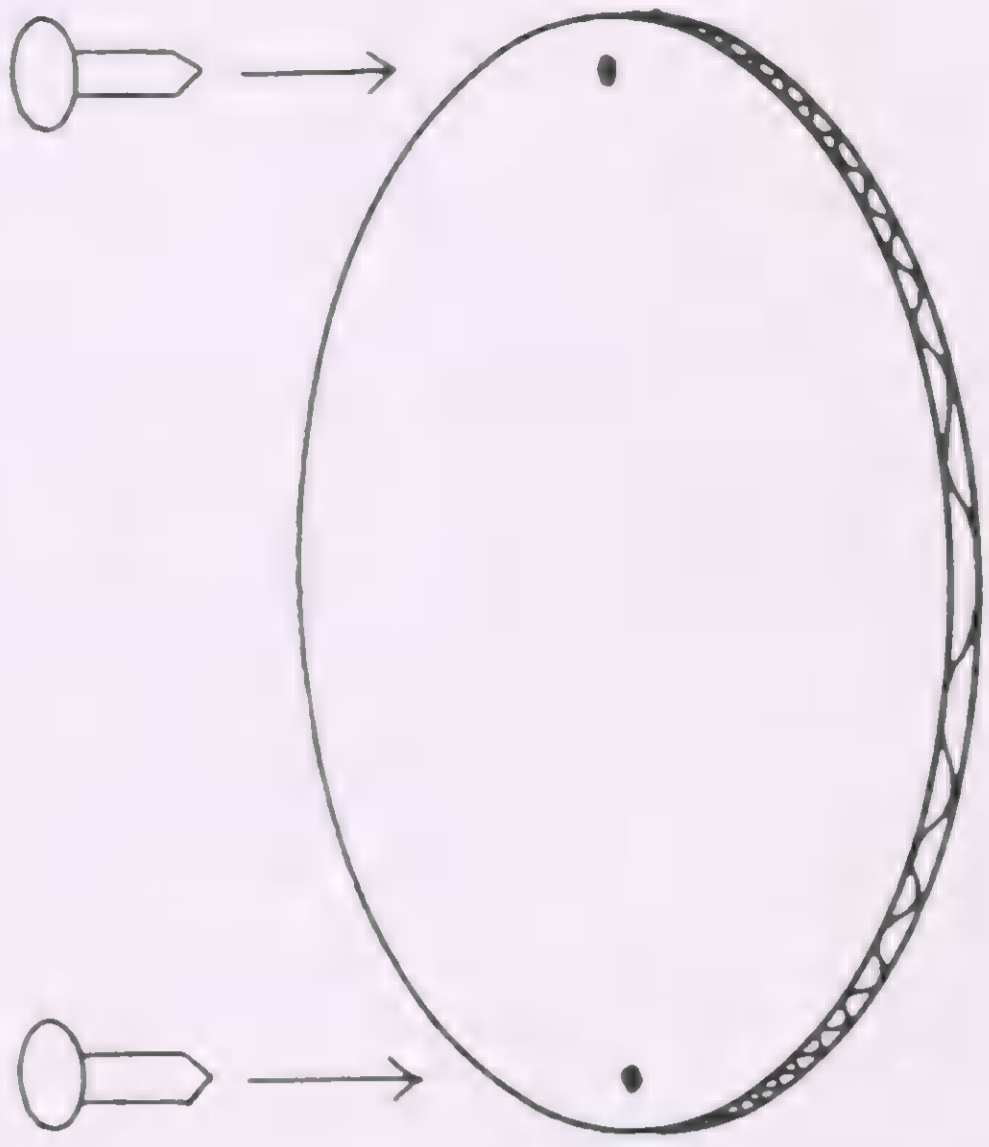

**STEP 6:** Insert a brass paper fastener into each hole of the uncut cardboard disk. This blank disk will be the spinner *face-plate*.

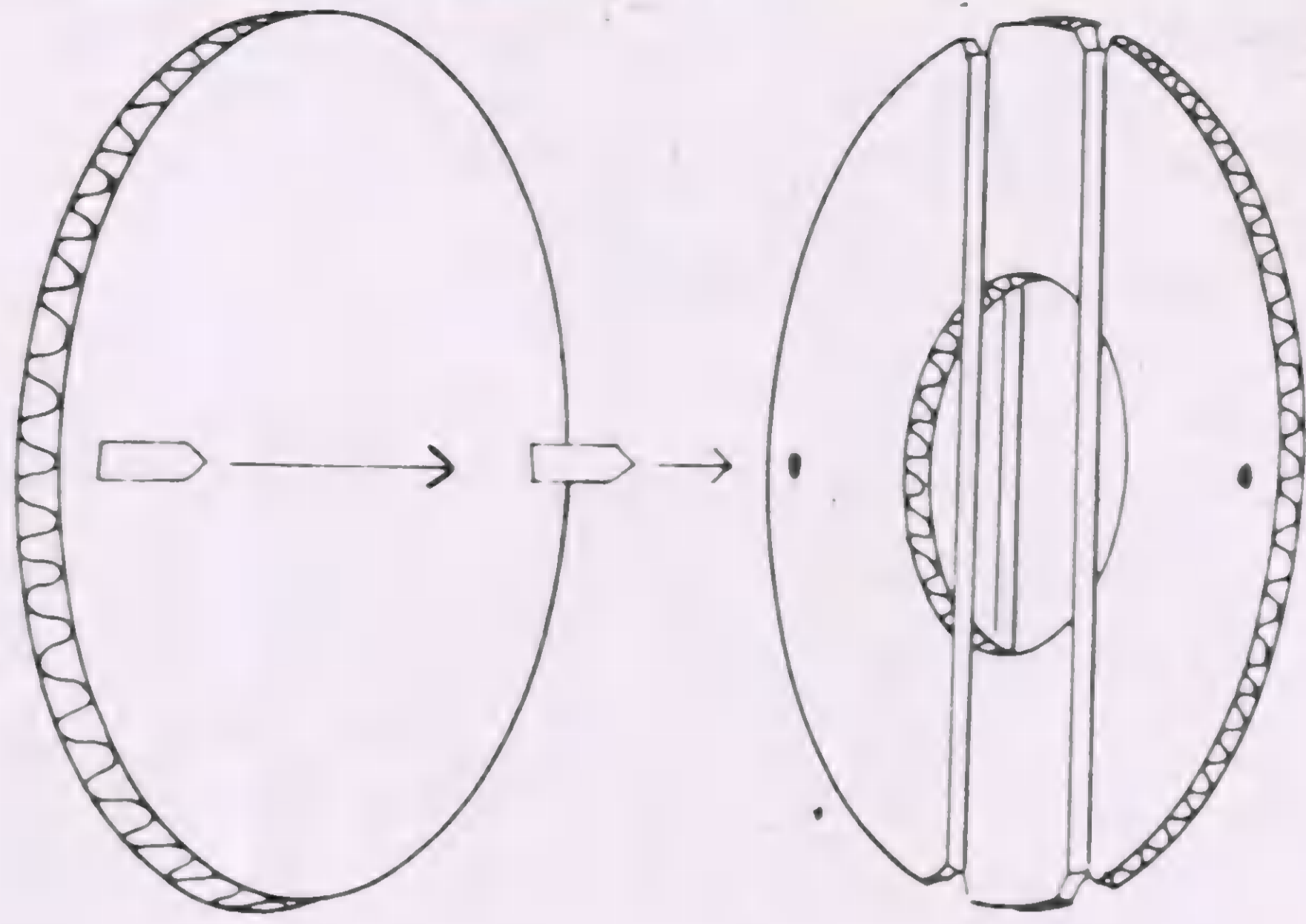

**STEP 7:** Guide the protruding fastener points into the matching holes in the spacer ring. Spread each fastener to firmly anchor the face-plate disk against the spacer ring.

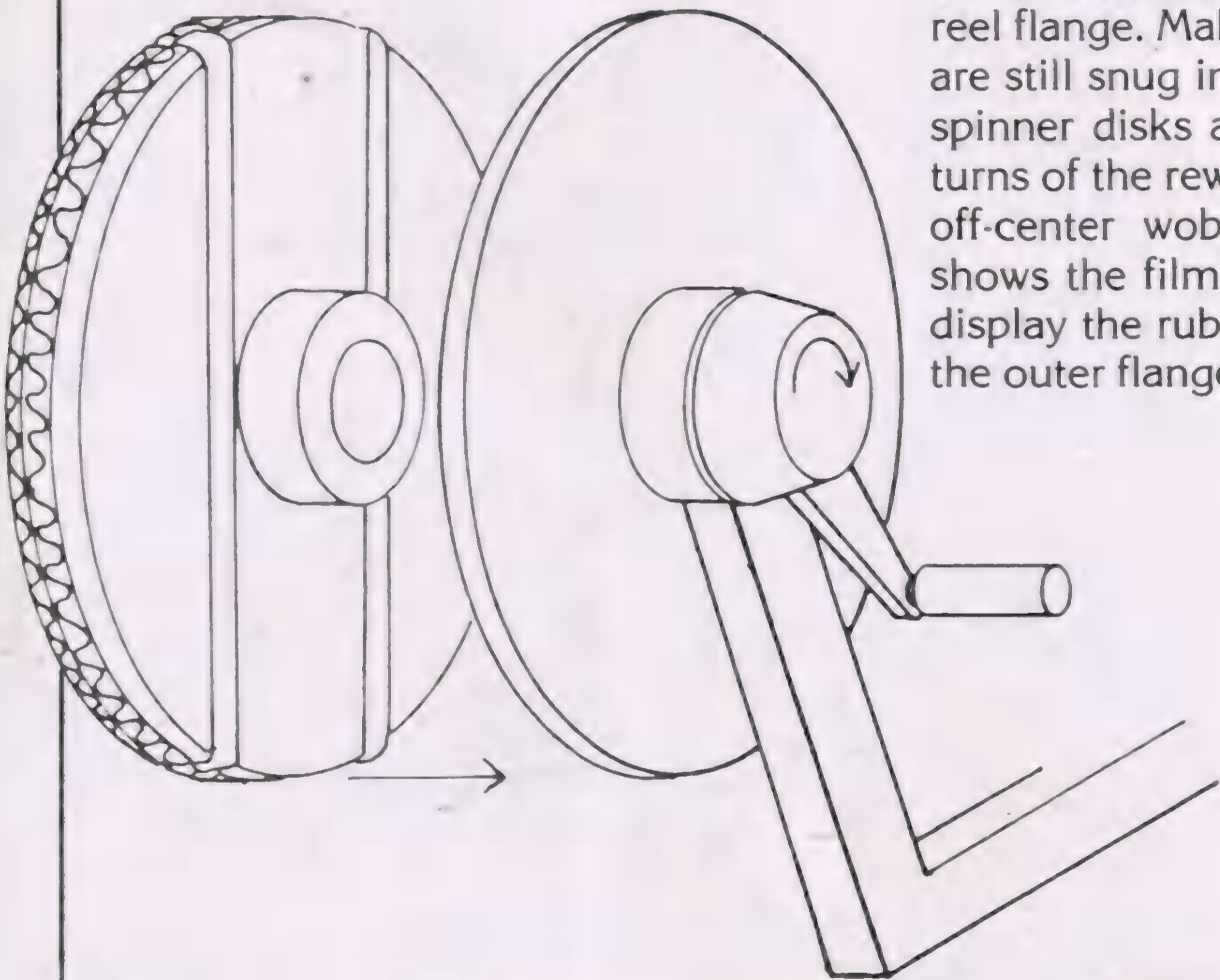

**STEP 8:** Place the plastic reel onto the rewind shaft of the film editor and lock securely. Take the cardboard spinner disks and hold them next to the film reel. The spacer ring should be face-to-face with the film reel's front flange. Slip the spacer ring's rubber band loops over the flange rim. A long pencil can help stretch the second band into place around the reel flange. Make sure that the two bands are still snug in the notches and that the spinner disks are centered. A couple of turns of the rewind handle will reveal any off-center wobble. Note: This drawing shows the film reel flanges separated to display the rubber band arrangement on the outer flange.

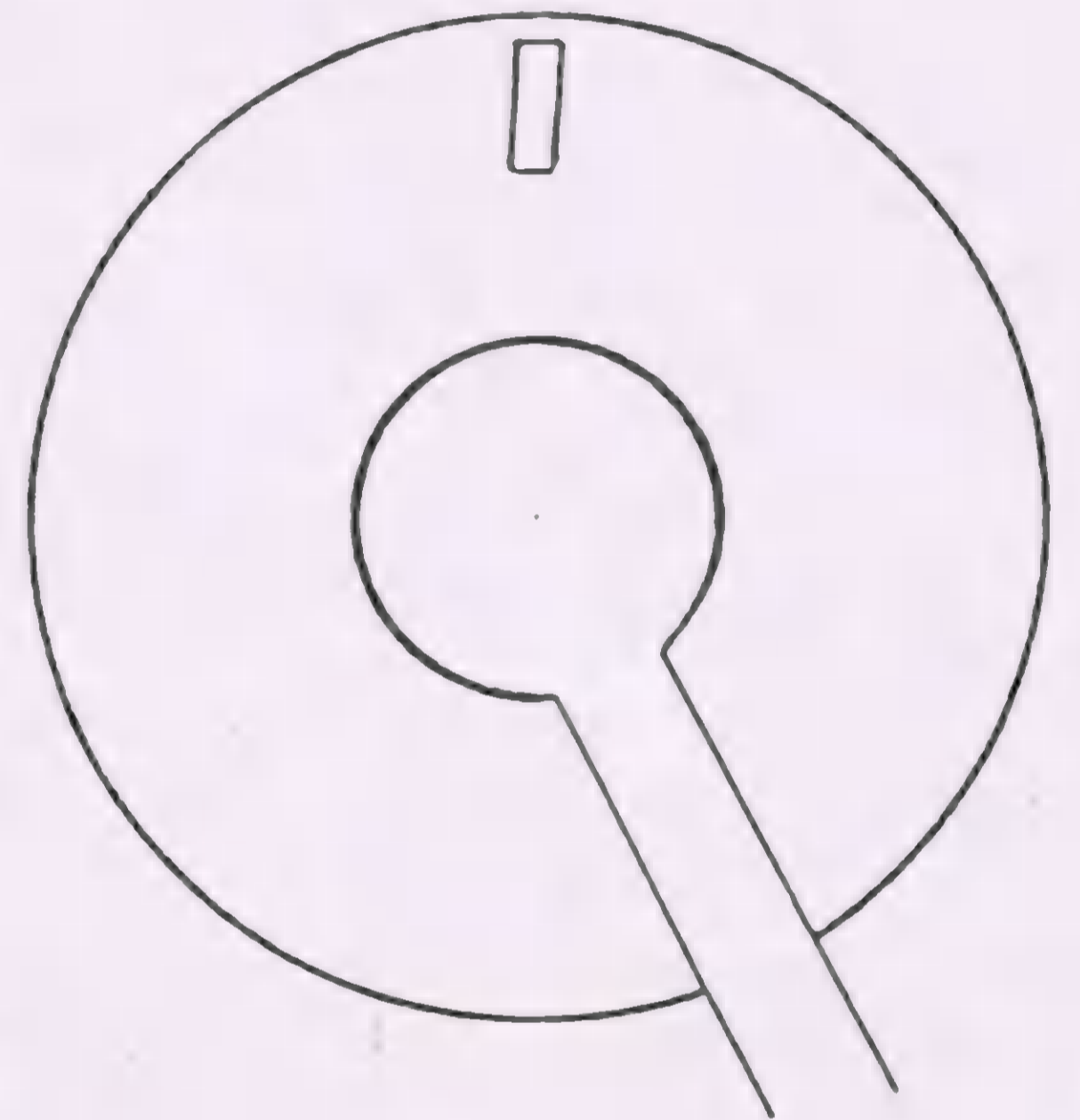

**STEP 9:** Apply a short vertical strip of adhesive tape to the reel flange top on the backside of the spinner. This visual indicator will help the spinner operator to judge when the title is right-side up and level.

**STEP 10:** Use the art paper circle traced in *Step 1* to make correctly sized title sheets. Titles can be lettered with a marking pen. If you prefer a more professional look, make the titles with dry-transfer alphabet sheets. These easy-to-apply lettering sheets are available in a wide variety of styles at most office supply stores. Don't forget that photographs can be cut to size and used as title backgrounds. Use short strips of adhesive tape to attach the sheets to the spinner face-plate.



**PHOTOGRAPHY:** The camera should be locked onto a tripod for a steady image. Set the lens position to extreme telephoto, or use a close-up attachment to give a good magnification of the small title sheet lettering. The editor should be squarely placed on a table no more than six feet from the camera lens. The photographer's assistant will operate the spinner. The title sheet can be filmed just like an ordinary title card. The light source can be bright sunlight or two photofloods on each side of the spinner. Overlap the photoflood beams at 45-degree angles to eliminate any shadows on the spinner face-plate. Now you're ready to add spinning titles to your next epic.

# Stop-motion STUDIO

## ARMATURES IN FOCUS

By JOHN DODS

**S**top complaining about those magazine armature photos that aren't clear enough or large enough to allow you to see exactly how the constructions were made. Your problems are over.

In this new, regular feature we'll be giving you a very good look at the varied techniques used in armature fabrication through the use of big sharp photos and very little else.

This issue we are featuring young animator Ken Brilliant's steel and aluminum armature for his version of an alien creature. (See CINEMAGIC #21 for Ken's article on the foam rubber build-up method of stop-motion model construction.) Ken is studying animation and filmmaking at the School of Visual Arts in New York City.

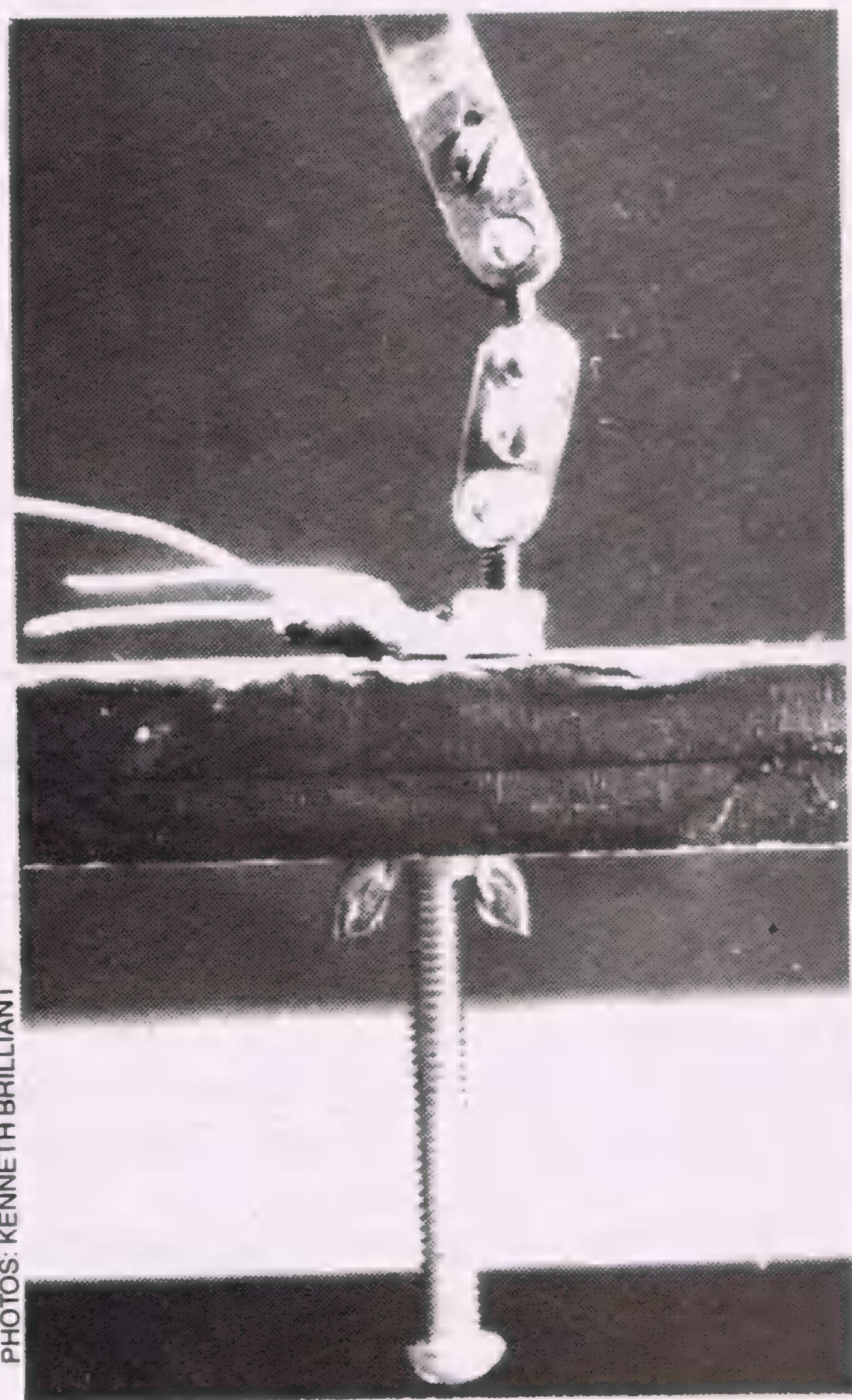

PHOTOS: KENNETH BRILLIANT

This "tie down" holds the model's foot firmly in place. A bolt is turned into a taped hole in the armature's foot. Then, a wing nut is turned to tighten the foot firmly against the board.

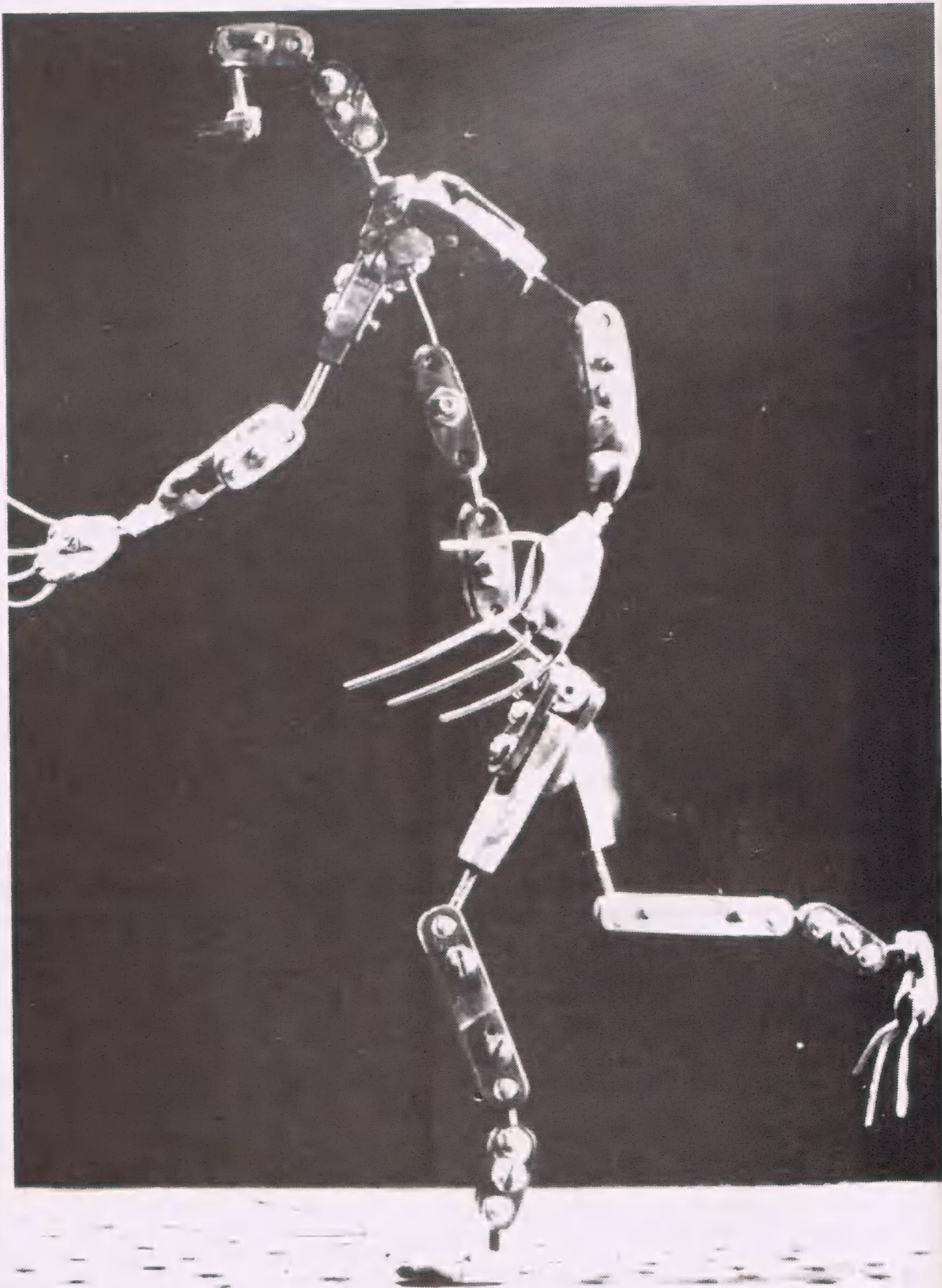

Ken Brilliant machined this steel and aluminum armature using an \$80.00 Shopcraft drillpress purchased at Rickle's. The aluminum wire fingers are held in place with epoxy putty.

The aluminum ball bearings sit in sockets that were first drilled, then countersunk, and finally milled with a "ball mill end." Note that some balls are attached to threaded rod and others to smooth rod (lengths of nails). Ken finds that the threaded rod will sometimes twist loose and prefers to pound the aluminum balls onto smooth rod.

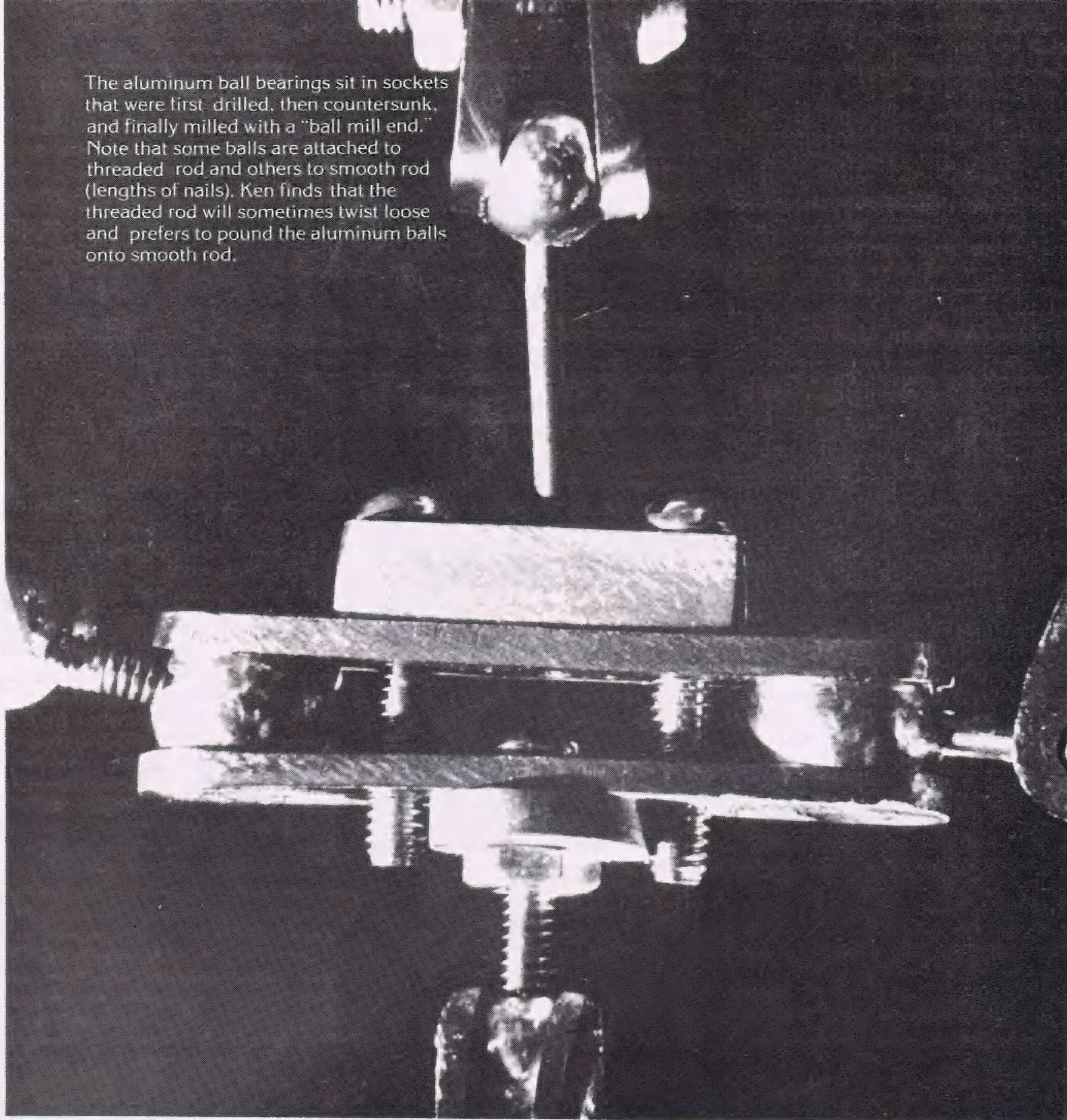

Ken used aluminum ball bearings because they are both easy to drill and adequately wear resistant. The bolts shown here protrude through holes that have been threaded with a hand tap and therefore do not need nuts at the ends. *CM*



# PROFILE

## Extended Play

### The Making of an Award-Winning Film

Director David Casci talks about his madcap game parlor comedy, which has won 49 Film Festival awards.

By JOHN CLAYTON

**T**he film that took top honors at last year's CINEMAGIC/SVA Short Search was *Extended Play*, a 16 mm short about an all-too-real video game that was made by a group of San Francisco Bay area film students led by director David Casci and producer Chris Perry. *Extended Play* is absolutely hilarious and is a real crowd pleaser. According to director Casci, the film has

won 49 awards at national and international film festivals, many of them top honors, in addition to winning first prize in the 16mm category of the CINEMAGIC/SVA contest.

"I got the idea for the film in a fitful dream," David Casci begins. "I was just lying on my bed, staring at the ceiling when a bolt of inspiration hit me. The concept of a comedy full of sight gags about a video game that runs amuck seemed like a potentially very funny film. *Extended Play* was made as a student film at DeAnza College in Cupertino, California. I told some of my fellow film students about my idea and they all expressed interest in working on it. Although the original idea was mine, Chris Perry, John Nystrom and Dean Woolman all contributed to the script and the making of the film. Someone would think of another gag and we'd incorporate it."

The result is a film so full of sight gags that it takes more than one viewing to pick up on them all. The game parlor is full of games with names like "Firing Squad", "Hit and Run Driver" and "Sink the Good Ship Hope" (a variation of the ever popular submarine torpedo game). The star attraction in *Extended Play* is an air combat game called "Mig Alley", a brand new game from Acme Amusements (whose motto is: "If isn't Acme, it isn't amusing"). The game gets out of hand when the lead character—the first to play the new amusement—inserts a dollar and discovers that the enemy planes he's supposed to shoot down are fighting back with real bullets. The game room suddenly becomes a disaster area as stray bullets rip through everything in sight, including many a game player.

"The storyboards were done by Frans Vischer, who also made all of the headboard paintings of the other bogus games in the parlor. Frans is now an animator at Disney," David continues. "The storyboards helped as a reference on the set and gave us the option of im-

provising and knowing that it would all cut together. There are about a hundred shots in the finished film that weren't in the storyboards, but you probably couldn't tell even if you went back and looked at the storyboards because they were mostly quick inserts.

"I really never added everything up to get a concrete figure on how much *Extended Play* cost, but I would guess that it



The change booth lady in *Extended Play* picks her nose and eats it. Here she's found something yummy.



Actor John Pierce turns in a memorable performance as Nerdly McWhiteboy, the gawky protagonist.

wound up costing about \$15,000," David confides. "The production money came out of the pockets of the four principal people involved, plus from Robin Frank, who designed and built our rear projection effects rig. DeAnza College also helped out with a small loan and, of course, the use of their equipment.

"*Extended Play* was shot over the course of about one year," David continues. "We shot the game parlor interior establishing shots in four different game parlors, including the company game room at Atari in Sunnyvale. This helps make the parlor look very large, but it was also a result of not being able to film in any one place for very long. As a matter of fact, it took us a year to get permission to shoot in the ice cream parlor, which is where the film begins. We had to shoot the first scene in the film last because of the trouble we had securing the ice cream parlor location.

"Of course, all of the destruction takes place on a set we built for the film," David reveals. "All of the pinball games that get shot up are light-weight props. The explosions were handled by Rob Roberts, who had been a demolition expert in the navy. Of course, the explosions weren't nearly as impressive on the set as they appear in the film. They didn't make any noise, they were just flashes of light and smoke. As a matter of fact, the entire film was shot M.O.S. (without live sound) because we wanted to create a cartoon-like mood. We loped in all the dialog and sound effects in post-production.

David edited both the sound and the picture and has won several awards for editing at the film contests in which *Extended Play* was entered. "Actually the soundtrack took longer to cut than the picture," David confides. "There were nine tracks running during the final mix and some of those had been mixed down from several other tracks. In all, I'd say there were about 32 different tracks to the sound. Each track was cut separately on a flatbed. The first time I could hear all of the tracks together was at the lab during the final mix."

The lead actor, John Pierce is perfect for the part of Nerdly McWhiteboy, a total nerd who can't do anything right except play video games. Pierce's fine performance is critical to making the comedy in *Extended Play* succeed. "We had a casting call and used a lot of students as extras, but I didn't find my lead until I saw John Pierce miming *The Rocky Horror Picture Show* at a midnight performance at a local movie theater in Berkeley," David recalls. "He's in New York now pursuing an acting career and he may have a leading role in an upcoming feature. John is really very different from the character he plays. During the year that we were shooting *Extended Play*, John was heavily into the punk rock scene and

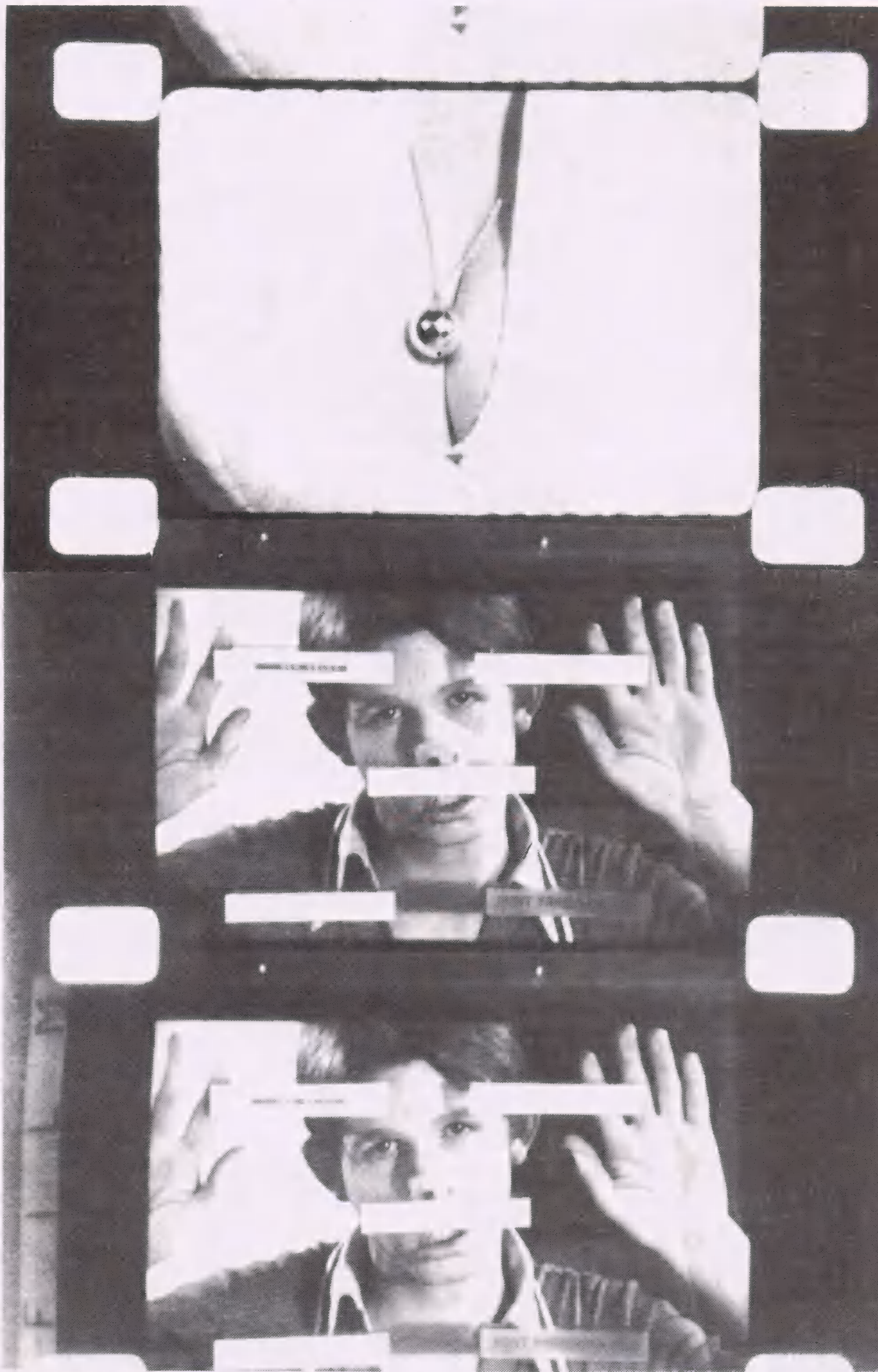

We quickly discover why Nerdly, seen gesturing on the opposite page, wants two scoops of ice cream. The clever lad uses this ruse so he can once again follow the bouncing ball worn on a chain by the comely ice cream parlor counter girl, Dee Dee Dippenscoop, played by Vicki Piper.

every time we were ready to shoot he'd show up with a new wild color of hair. We had to bleach his hair blond and then dye it back to the original color that he had when we began shooting. He was always very cooperative and he turned in a fine performance, but it was a continuity nightmare to see him show up for a shoot with a wildly colored punk haircut. He also kept gaining and losing weight during the course of the production, which we had to do our best to disguise.

"The first thing that we shot in making *Extended Play* were the effects shots of the planes seen on the screen of the *Mig Alley* game," David discloses. "The shots of the attacking planes were shot in live action. Wayman 'Russ' Perry built a special over-head dolly rig [a suspended gimbal mount] that we used to dolly in on the planes and for the shot where the plane goes into a crash dive. The crash dive shot employed a six-by-eleven-foot forced perspective miniature landscape



Vicki Piper plays Dee Dee Dippenscoop in *Extended Play*. The film has won 49 film festival awards, among them: The Los Angeles International Film Exposition (Filmex '82) — Best Short; London International Film Festival — Best 16mm, Best Editing; 1983 Velden Film Festival, Austria — Gold Medal, Best Editing.

designed and built by Dean Woolman. Dean was our special effects man, although we all worked on the effects as well. John Nystrom was our cinematographer, but Chris Perry and I also did a good deal of the shooting. The miniature landscape was detailed with an airport, highway, town and mountains and included small hidden explosive charges to simulate hits by missile and machinegun fire. Dean also constructed a 15-foot-long and seven-foot-wide and high 'tunnel' of black velvet to film the cloud effects. The camera was mounted on a conventional dolly for the cloud effects footage and pushed through the tunnel, which was lined with suspended dacron 'clouds.' When superimposed with the other elements for the flying effects shots, the effect of an aircraft flying through clouds was achieved. The model planes—kits built by Bob Yeomans, came complete with fiberoptic strands to simulate machine gun fire and were suspended from the ceiling of the set by wires. Machineguns and missile fire was optically added to some of the effects shots.

"Once we had completed our flying effects shots, we had to devise a way to rear project them in live action in sync with the camera," David reveals. "Robin Lee Frank designed a rear projection system for this purpose because we were unable to rent a rear projection system that would project in sync with the camera. The 'Frank-Flex' system consisted of a 1932 model Kodak projector that had

been modified with a more powerful light source, power ventilation assisted by a refrigerated water pumping system and also a film transport re-design. The heart of the 'Frank-Flex' was a complex electro-mechanical flywheel sync generator coupled to an intricate sync circuit, and ten simultaneously-triggered solenoids releasing the camera's shutter. A Bolex camera was synced to the 'Frank-Flex' and the effects were then rear projected onto the screen of the 'Mig Alley' game. In this manner, we were able to simultaneously film the rear projected flying effects with the flashing lights of the cockpit control panel on the 'Mig Alley' game.

Some of the victims in *Extended Play* squirt blood in a very cartoon-like fashion. If you've ever seen a cartoon character drink a glass of water after being shot many times, you can imagine what the bloodshed looks like in *Extended Play*. There's even a gag in the film involving a woman in an electric wheelchair who gets shot and spends the rest of the film crashing into pinball games and knocking them over. The violence in *Extended Play* is brutally funny.

"We were striving to create a cartoon-like quality to the film," David continues. "That's why the victims bleed so profusely in an unnatural manner instead of just oozing blood from their wounds. We even thought of using different colors instead of red to keep the blood from looking real, but we decided that that would probably look more grotesque than red

blood. We wound up using a bright fire engine red acrylic paint in an effort to keep the blood from looking real. We placed explosive squibs on the actors to effect the bullet hits and had the blood come gushing out through tubes under the actors' clothing. The tubes were connected to Black & Decker 'Jack-Rabbit' pumps, which put out enough pressure to make the blood come shooting out in high pressure streams." The effect looks sufficiently fake (and humorous in a macabre way) to avoid changing the comedic mood of the film.

In addition to explosive squibs, wires were used to effect bullet hits. Pieces of chairs and other props were cut off, attached to wires, and delicately put back into position. When it came time to effect the bullet hit, the wire was simply yanked and the piece went flying out of the frame. One advantage of this technique is that you can usually do as many takes as you need to get the effect "right," where as with squibs you usually ruin the prop with the first take. The wires have to be extremely thin so they don't show up on the screen, and it helps to match the color of the wire with the color of the background. Many of the effects in *Extended Play* employed the use of wires and most of the wire work was done by David and producer Chris Perry.

There's a great little bit of stop-motion animation in the beginning of the film in which John Pierce's character (Nerdly) finds an ant on his ice cream cone after falling on his ass after being distracted by



a couple of pretty girls. The indignant ant spouts some unintelligible gibberish and then jumps off of John's hand and runs away.

"I made the animation model of the ant, and it's only 3/4-of-an-inch tall!" David exclaims. "It was so small that I had to manipulate it's limbs with surgical tweezers to animate it. The hand is a latex casting of my own hand and the background is a still that our still photographer, James Owen, took on location. It's a throw-away scene—it's only a few seconds long—but it's good for a laugh. As a matter of fact, many of the cones seen in the film (all representing the same cone) are latex cones because of the problems of ice cream melt-

ing—especially under hot lights. The only real cones used are the visibly drippy ones."

Another throw-away scene that's extremely funny happens when Nerdly (John Pierce) shoots down an enemy plane, but not before the pilot can eject. The audience sees the pilot escaping the plane just as it explodes. The pilot's parachute opens, and he lands right on the windshield of Nerdly's plane. The North Korean pilot (an extreme caricature with giant buck teeth and tiny slanted eyes) presses his nose flat on the glass of the cockpit canopy and starts screaming some oriental-sounding gibberish. A cockpit light goes on instructing Nerdly to turn on his windshield

wipers. That does the trick. It's a hilarious little bit, and it only lasts a few seconds, but it took the better part of an afternoon to shoot.

"We originally had an oriental for the shot," David confides, "but he was too heavy for our rope and pulley rig. The pilot seen in the film is actually one of the four main filmmakers who worked on *Extended Play*, but I better not say which one or he'll kill me." This noble filmmaker, chosen for his light weight and diminutive size, turns in a memorable performance as a doomed comie pilot, even though he's only on the screen for a few seconds. It's a shame his true identity will never be known. For this throw-away shot, he had to dangle for hours over



Jeanne Payer plays a woman in an electric wheelchair that runs amok after she is hit by stray bullets from the Mig Alley game in a scene from *Extended Play*.



Another victim of stray bullets is covered with quarters that come gushing out of a pinball machine that falls on top of him. Kids soon descend like vultures.



A North Korean pilot shot down by Nerdly in the Mig Alley game manages to parachute out of his disabled mig only to land on Nerdly's cockpit canopy.

7000 watts of hot lights, wearing a sweaty aviator jumpsuit. That's the kind of dedication that goes into making an award winning film.

Towards the end of the film it becomes obvious to Nerdly that the only way he can escape the constant waves of enemy Migs is to activate his own ejection seat and hope for the best. Otherwise he's doomed because he can't get out of the "quick release" seat belts that hold him in a position of certain doom. When he ejects he escapes straight into the ceiling



Dean Woolman designed and built a forced perspective miniature landscape for the crash dive shot, complete with an airport, highway, town and mountains.

ten feet above him. The final shot in the film is his parachute unfurling while the ejection seat remains crashed through the ceiling, with only the lower half of Nerdly's body visible.

"The shot of the parachute unfurling and falling to the floor, which was the last shot in the film, turned out to be a real headache," David recalls. "We shot it several times, but the parachute just kept falling to the floor in a clump. We wound up shooting the unfurled parachute and making the transition from the parachute beginning to fall to it unfurling with an optical. We used a hand-painted traveling matte to achieve the effect. I'm not totally happy with the shot, but I think that only a very astute eye can perceive how the shot was executed."

David and producer Chris Perry built a special animation stand for the closing credits of *Extended Play*. The credits are backlit, and as they scroll up the screen, an animated bouncing ball keeps the audience in time with the lyrics of the closing song, "Penny Arcade." The stand had to have a sliding base to facilitate the animation of the bouncing ball.

"We have permission to use 'Penny Arcade' (by B. & F. Bryant, sung by Cristy Lane) free of charge for festivals," David reveals. "We have to pay royalties for any paid distribution of *Extended Play*. We have a distributor, Future Vision in Chicago, to handle Cable distribution and *Extended Play* may be released for the home video market in the near future. It may also be released theatrically as a part of an anthology of sci-fi comedy films, along with my earlier 16mm short *Poppin' Flesh* which is a parody of the Pillsbury Doughboy. Pillsbury's lawyers are looking into whether they'll allow *Poppin' Flesh* to be released. I can appreciate that they want to protect their copyrighted character.

*Extended Play* was completed in October of '81 and released to the film festival circuit in early '82. Since that time it has received 49 awards at film festivals around the world. "We made 25 prints for distribution to festivals," David remembers. "We're very happy at the response that the film has received. We've turned over the distribution of the film to festivals to a distributor called Cine, which is located in Washington. It's nice to occasionally hear from them that *Extended Play* has won another award."

Three of the four makers of *Extended Play*—David Casci, Chris Perry and John Nystrom—are currently developing a 35mm feature for theatrical release. "It will be a comedy," David reveals. "But it won't be as fast-paced or as slap stick as *Extended Play*. I don't think anyone could take that kind of pace for the full length of a feature."

If their next film gets off the ground and is as good as *Extended Play*, we'll all be hearing from them.



PHOTOS COURTESY OF DAVID CASCI PRODUCTIONS

The filmmakers on location at the Atari game room in Sunnyvale, California. From left to right: David Casci, John Nystrom (behind camera), Dean Woolman and Chris Perry. The four all collaborated on the script and put up money to produce the film. David Casci directed, Chris Perry produced, John Nystrom was cinematographer and Dean Woolman was the special effects supervisor.

# MOVIE SOUVENIR PROGRAMS!

For a limited time only, we are able to offer to STARLOG readers souvenir programs from some of the best SF and fantasy films ever! These are the official programs that were sold in theaters at the time of the films' original releases. Each magazine is 20 pages, measures 9" x 12" (with the exception of *RAIDERS OF THE LOST ARK*) is printed on heavy paper and features complete cast, credits, actors' bios, production notes and dozens of photos.

Now out of print, only a limited number of each is available—so it's strictly first come, first served! Don't be disappointed, order today!

**RAIDERS OF THE LOST ARK**  
8¼" x 11", 64 pgs. Color pic.  
Maybe best program ever!



**BATTLESTAR GALACTICA**



**STAR TREK: THE MOVIE**



**STAR TREK II: WRATH OF KHAN**

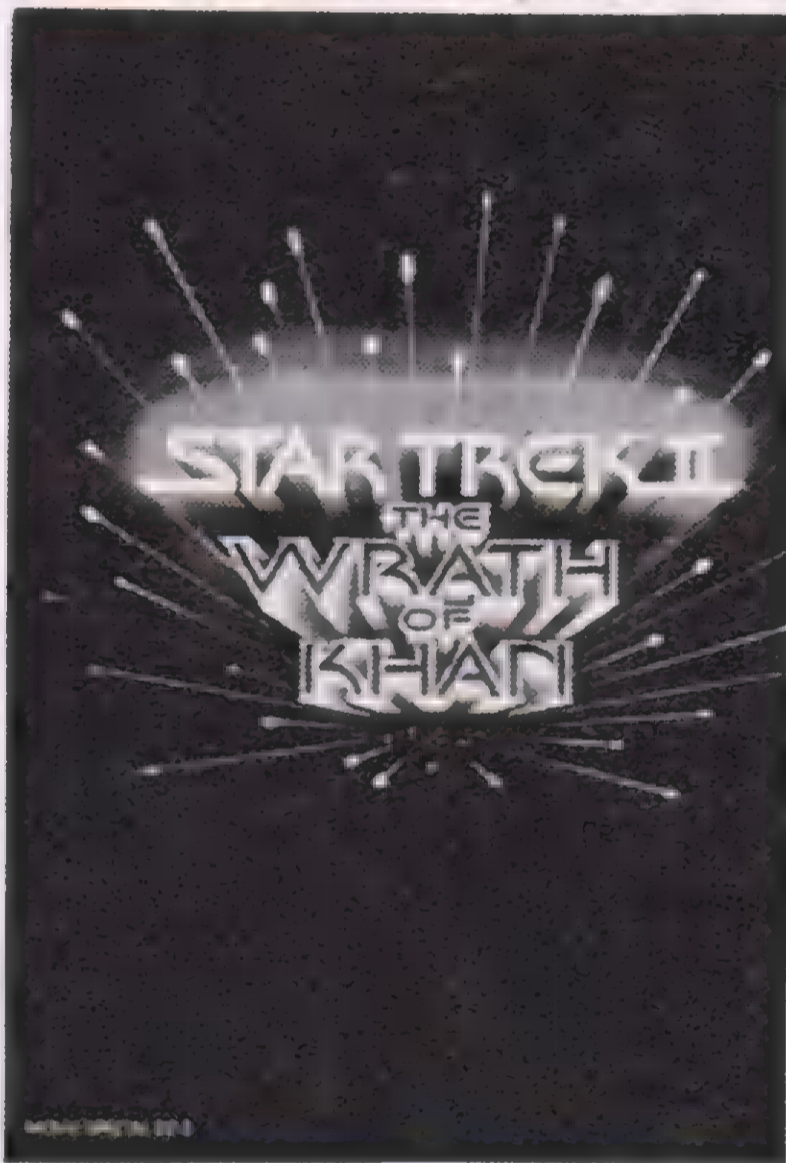

**SUPERMAN II**

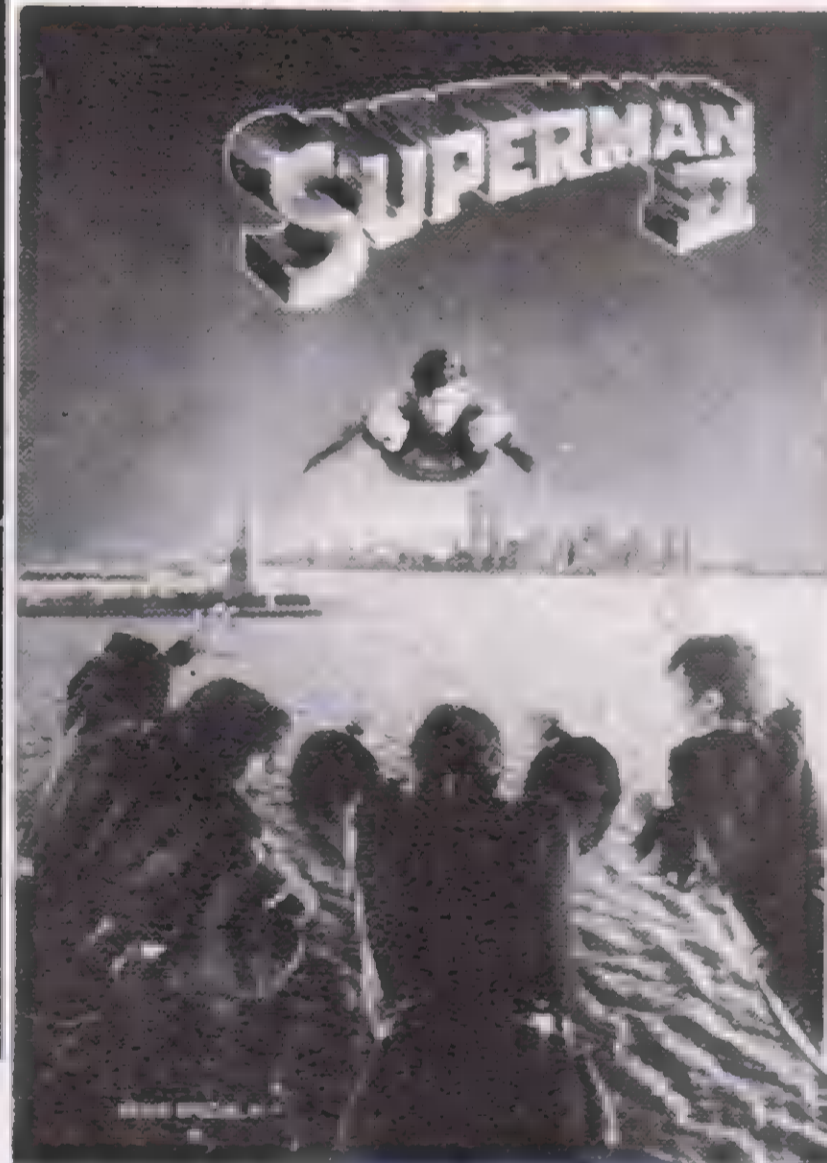

**ALIEN**



**INVASION OF THE BODY SNATCHERS**

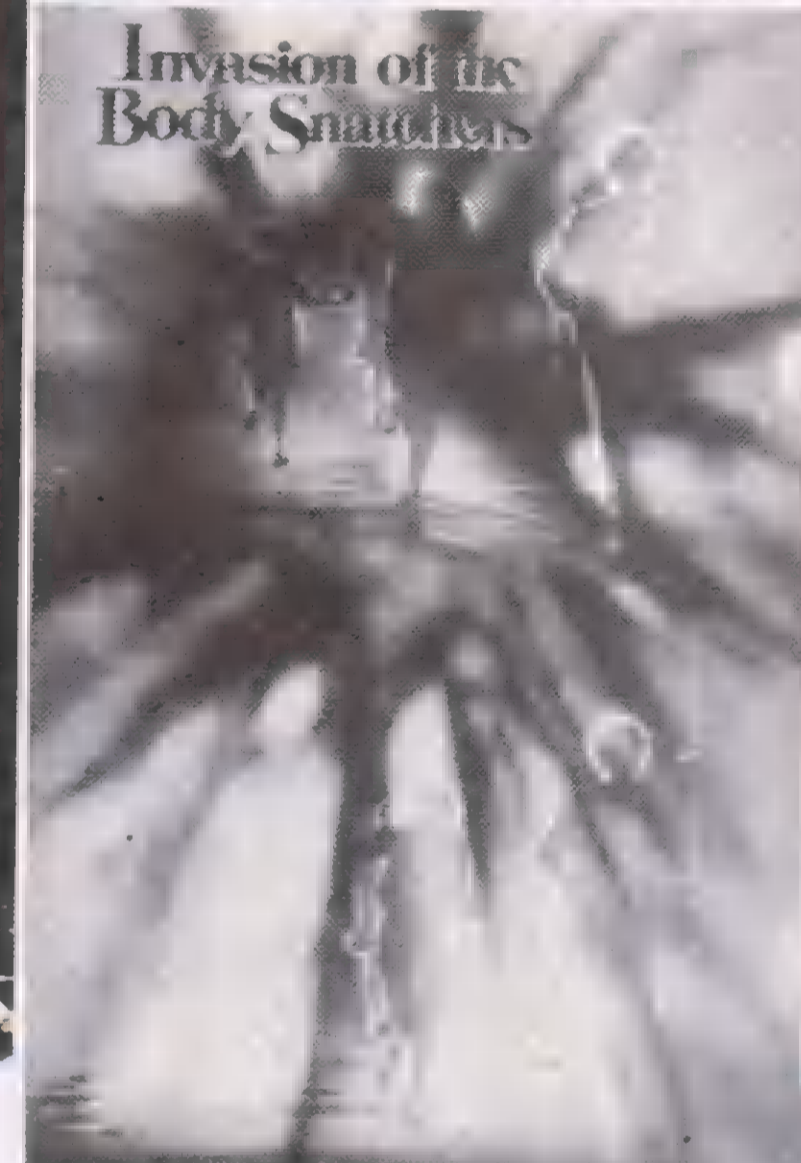

**CLOSE ENCOUNTERS OF THE THIRD KIND**

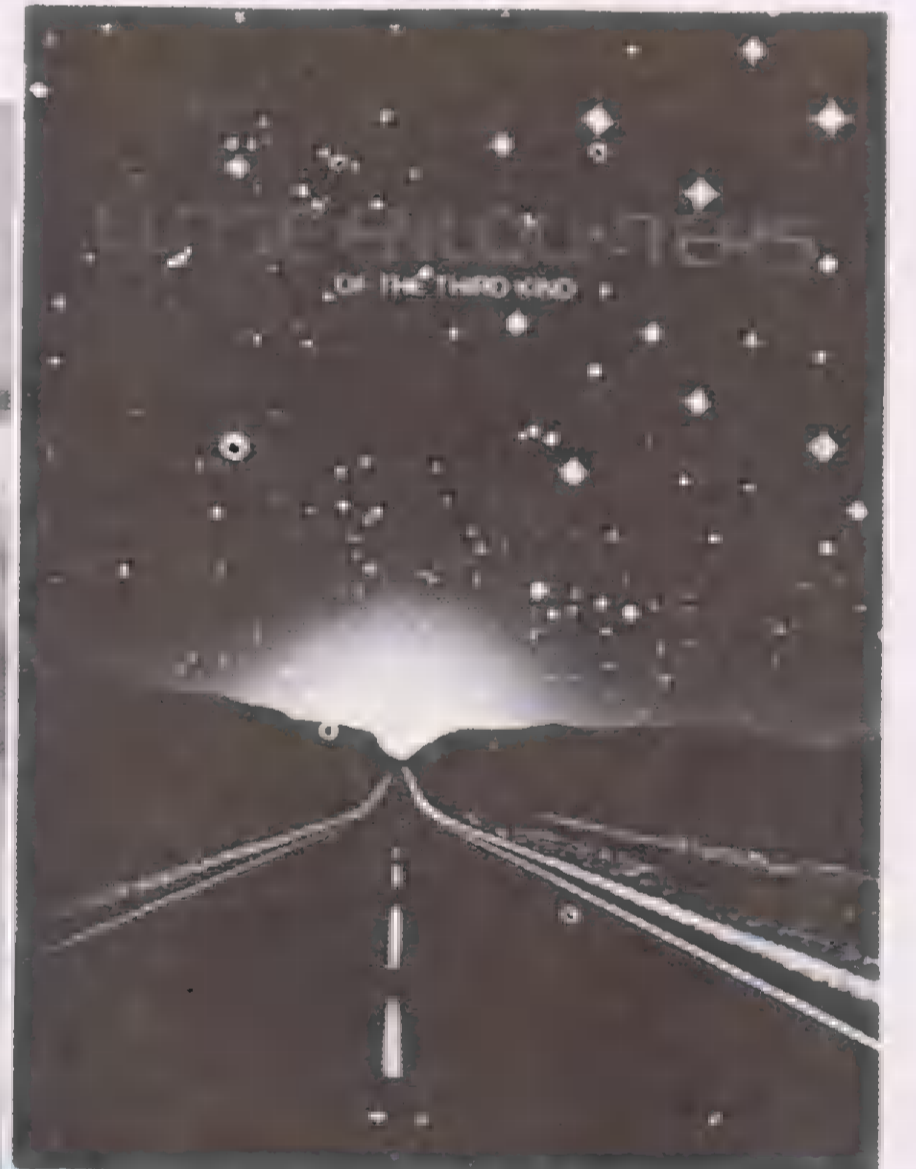

**ALSO AVAILABLE:** BUCK ROGERS FLASH GORDON THE SPY WHO LOVED ME MOONRAKER THE DARK CRYSTAL HEAVY METAL LORD OF THE RINGS SECRET OF NIMH DRAGON SLAYER DRACULA JAWS 2 POPEYE

## CLIP OR COPY

Send cash, check or money order to: **STARLOG PRESS 475 Park Avenue South New York, NY 10016**

In box, please indicate quantity of each desired.

**\$5.00 + \$1.00 postage**  
 RAIDERS OF THE LOST ARK

DRAGONSLAYER  
 THE SECRET OF NIMH  
 POPEYE

ALIEN  
 INVASION OF THE BODY SNATCHERS  
 THE SPY WHO LOVED ME  
 BUCK ROGERS  
 MOONRAKER  
 THE LORD OF THE RINGS  
 DRACULA  
 JAWS 2

**\$3.50 + \$1.00 postage**  
 STAR TREK II: WRATH OF KHAN  
 SUPERMAN II  
 THE DARK CRYSTAL  
 FLASH GORDON  
 HEAVY METAL

**\$3.00 + \$1.00 postage**  
 STAR TREK: THE MOVIE  
 STAR WARS  
 CLOSE ENCOUNTERS OF THE THIRD KIND  
 BATTLESTAR GALACTICA

NAME \_\_\_\_\_

ADDRESS \_\_\_\_\_

CITY \_\_\_\_\_

STATE \_\_\_\_\_

ZIP \_\_\_\_\_



# LIGHTS! CAMERA! ACTION!

*Leonard Nimoy hosts a show on the Nickelodeon cable channel that takes a behind-the-scenes look at major movies.*

**S**tandby...Lights! Camera! Action!" is a series of 12 one-hour shows on the Nickelodeon cable channel that takes viewers behind the scenes of major motion pictures and examines how movies are made. The show should especially interest CINEMAGIC readers because a variety of special effects are explored by host Leonard Nimoy and his guests. Past guests have included a mechanical effects technician, a professional stuntwoman and others whose profession is some fascinating aspect of filmmaking. Nimoy invariably has his guests demonstrate the tricks of their trade.

Recently, CINEMAGIC Publisher Kerry O'Quinn appeared on "Standby...Lights! Camera! Action!" to talk about the CINEMAGIC/SVA Short Film Search. CINEMAGIC Editor-in-Chief David Hutchison also appeared on the

show and demonstrated a few simple special effects that CINEMAGIC readers should be familiar with, among them: miniature rocket exhaust, miniature explosions, making a raygun from household items, and creating a cobweb effect. Damon Santostefano, a 1980 CINEMAGIC/SVA winner appeared on a segment aired in August and talked about his winning film *Roublex O.M.F.* and his aspirations of directing feature films. Joey Ahlbum, a 1982 winner of the CINEMAGIC/SVA Short Film Search, has also appeared on the show to talk about his film, *Bandits*, and his career in the animation field.

Produced exclusively for Nickelodeon, "The First Channel for Kids," each hour examines three films; the principals involved are interviewed; the stunts and special effects are demonstrated; and

every detail, right down to makeup and costumes, is explained in such a way that fantasies are preserved, curiosity is heightened and awe of the silver screen is intensified.

"Standby...Lights! Camera! Action!" fulfills the need created by the proliferation of films aimed at young audiences. The fantastic qualities of these films has created a desire in many young people to learn how movies are made. That desire is in the heart of every CINEMAGIC reader, and "Standby...Lights! Camera! Action!" provides a rare opportunity to sample the methods behind the magic of today's blockbusters.

Films featured in the series include: *E.T.*; *Star Wars*; *The Empire Strikes Back*; *Revenge of the Jedi*; *Annie*; *Superman III*; *Black Stallion II*; *Wonder Woman*; and *Raiders of the Lost Ark* sequel. **CM**

Joey Ahlbum (left) demonstrates how he executed an animated pan shot for his CINEMAGIC/SVA award winning film *Bandits* while CINEMAGIC Publisher Kerry O'Quinn (center) and "Standby...Lights! Camera! Action!" host Leonard Nimoy (right) look on. The segment was aired in August on the Nickelodeon cable TV channel.





Leonard Nimoy watches as CINEMAGIC Editor-in-Chief David Hutchison demonstrates how to construct a ray-gun prop from simple household items.



Professional stuntwoman Lisa Cain demonstrates with Nimoy.



David Hutchison demonstrates cobweb effects with Nimoy on "Lights! Camera! Action!"



Damon Santostefano, who directed *Rouflex O.M.F.*, talks with Nimoy about filmmaking.

PHOTOS COURTESY OF NICKELODEON

# GRIP KIT

ing device, such as transparent, masking or gaffer's tape, paper clips, or clothespins.

Stik-Up is designed to be placed in those unusual, out-of-the-way places where a light source is required, but where standard luminaires are too large and bulky to fit. For example, in such space-limited areas as a car's dashboard, inside of a practical lamp, to simulate candlelight, and so forth.

The Stik-Up luminaire is available from The Great American Market as an individual unit or in a three-light kit. The kit comes in a reusable, extra-strength cardboard carton, or may be purchased with an optional heavy-duty Excalibur custom case.

Detailed information on the Stik-Up and Stik-Up kit may be obtained from The Great American Market, P.O. Box 178, Woodland Hills, CA 91365; telephone (213) 883-8182.

sales tax. For additional information, please call or write: Birns & Sawyer, Inc., 1026 N. Highland Avenue, Dept PR, Hollywood, CA 90038. Telephone: (213) 466-8211.



## POWER PACK

Responding to the consumer demand for a highly rechargeable, lightweight power source capable of delivering up to eight hours of portable VCR (video cassette recorder) operating time, Enerlite Products Corp. has introduced the Enerlite Marathon 10, a 3.5 pound nickel cadmium power pack. Enerlite is the developer, manufacturer, and distributor of quality products employing unvented nicad cells.

The Enerlite Marathon 10 is the first auxiliary nicad power pack designed specifically for the consumer market. According to the manufacturer's specifications, it can match or out perform any of the 12 volt, 4 amp pro-industrial power packs that typically sell in the \$500 range. The Marathon 10 has a suggested list price of \$169.95.

The Enerlite Marathon 10 weighs 3.5 pounds and is capable of delivering approximately 1,000-1,500 charge/discharge cycles and a 4-8 hour VRC range, depending on equipment used and battery condition. Other equipment on today's market with comparable applications weigh from 6-15 pounds, are rechargeable for a maximum of 150 cycles, and don't offer flame retardant construction. Additionally, in contrast to the current lead acid battery packs, the Enerlite Marathon 10 will not be damaged if over-charged or left discharged.

## STIK-UP™ LUMINAIRE

Stik-Up™—an ultra-compact, single-source luminaire—has been introduced by The Great American Market. Efficient and lightweight, Stik-Up weighs only nine ounces, with its lamp and nine-foot power cord.

Listing for only \$69.00, The Great American Market's Stik-Up uses a 100-watt, 3000° Kelvin lamp with a double-contact bayonet base. Accessories include extension arms which allow color media or diffusion material to be clipped in front of the Stik-Up to convert it to a soft light or a color-corrected fill light.

Stik-Up may be placed almost anywhere and may be fastened with any handy fasten-



## KELLY CALCULATOR

The Guild of British Camera Technicians in association with Kodak, Ltd., have re-designed the old Kelly Cine Calculator. Cinematography has developed greatly since the Kelly Calculator was first produced. The range of lenses and their aperture settings have vastly improved; film stocks and fields of view have changed. Metric dimensions are more commonly used.

The new Guild Kelly Calculator now includes the following scales: hyperfocal distance; depth of field; film usage; exposure compensation; and fields of view (including anamorphic).

The new Guild Kelly Calculator has a wider selection of lenses. The 35mm version features the following lenses: 18mm, 20mm, 32mm, 40mm, 50mm, 75mm, 85mm, 100mm, and 135mm. Extended features include a F/1 aperture, neutral density and color filters. The field of view scales for 35 mm contain Academy 1:1.33, Widescreen 1:1.85, and the Anamorphic 1:2.35 formats. Also available in a 16mm version.

The Calculator sells for \$20.00 plus \$2.50 shipping. California residents add 6.5%



## FLUID ACTION HEAD

The new Gitzo Fluid Action Head is suitable for Video and Cine cameras up to 10 lbs. offering exceptionally smooth fluid action panning of 360°, front tilting up to 30°, rear tilting up to 360°.

The strong, yet soft-touch tilt handle and the panning knob provide adjustment of the fluid action, as well as tight locking in any position. The head is 3½ inches high, has a soft cushioned ¾ inch x 3 inch platform for firm camera seating, and a T-shaped slit with a ¼-inch (or 3/8 inch) rapid adapter screw.

The uncompromisingly solid, heavy duty metal construction, without any breakable plastic substitutes nor unreparable riveting, withstands the most rugged use. Weight 1½ lbs. The Gitzo Fluid Action Head comes with a Full Five Year Gitzo Warranty Buyer Protection. CM

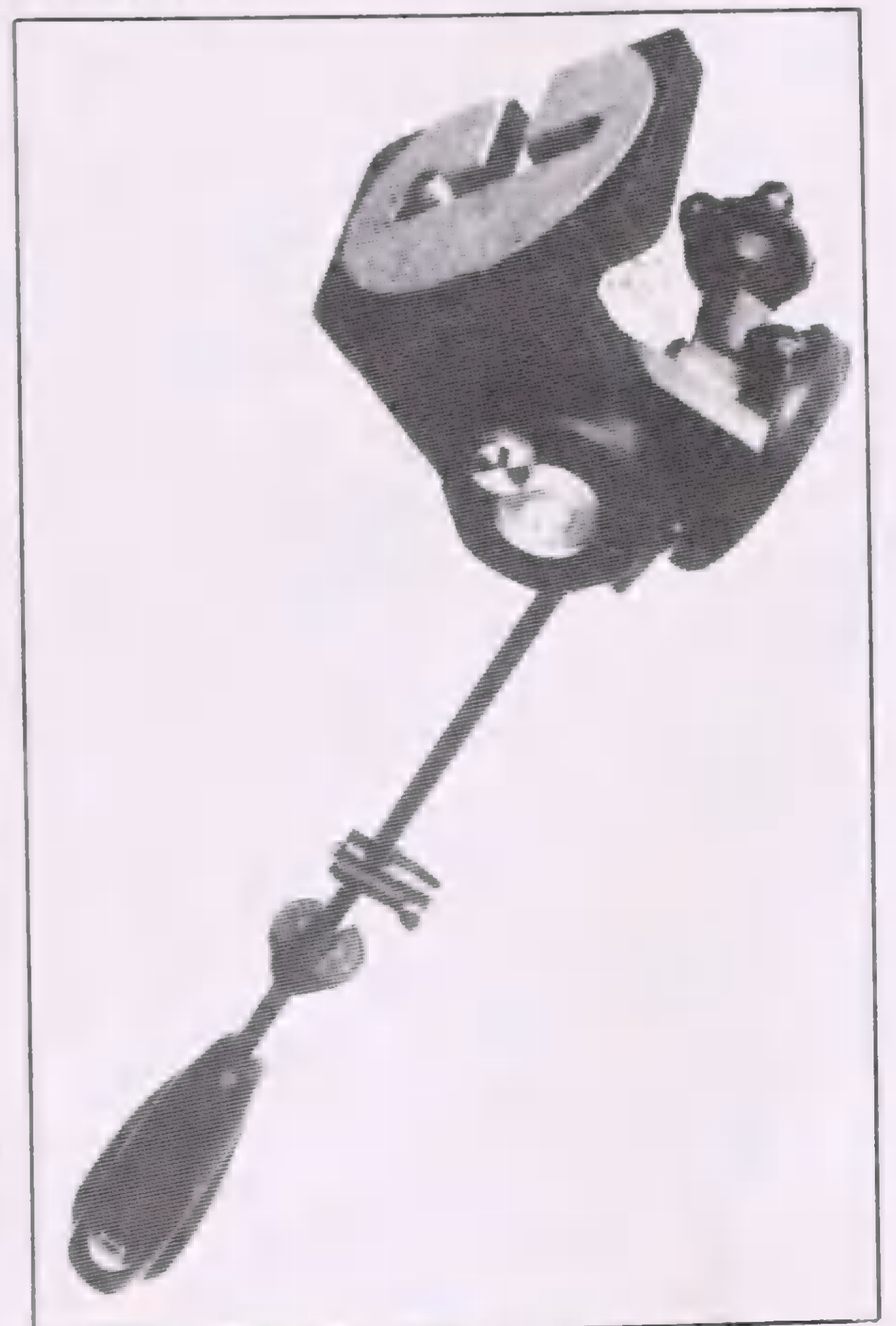

# BOOKS

**Cinema Workshop.** By Anton Wilson. American Cinematographer, Hollywood, CA. 5½" x 8½". 298 pages. \$8.95.

Anton Wilson's popular "Cinema Workshop" column in *American Cinematographer* magazine has just been anthologized into a comprehensive guide for cameramen in both the film and video mediums. Virtually every aspect of cinematography is covered, as well as informative coverage on the principles and techniques of sound recording. Mr. Wilson has organized his ten-year-old column into a very handy and informative volume that professionals will appreciate having around and from which film and video students will learn a great deal.

*Cinema Workshop* is broken down into chapters covering film, cameras, formats, lenses, filters, light, sound, batteries, underwater cinematography and video. Each chapter gets right to the heart of the matter by discussing first the theoretical aspects and then the practical applications of each respective subject. Mr. Wilson's writing style is very direct and informal and he has many years of experience as a cinematographer, director and producer to draw from and uses this experience to good advantage by relating his personal experiences to illuminate his points.

The chapter on film covers such subjects as: determining a film's resolving power by learning to read the Modulation Transfer Function (MTF) on the data sheet; determining the latitude of a film stock by reading the sensitometric curve on the data sheet; determining the granularity by reading the RMS (Root Mean Square) number supplied on the data sheet; plus tips on how to store film and relevant information on pitch and perforations, cores and spools and the mechanical properties of film.

The other chapters are similarly broken down and the various topics are comprehensively examined. Each chapter actually consists of many of Mr. Wilson's columns that have been previously published in *American Cinematographer*; each covering a narrow aspect of the overall subject in great depth. Mr. Wilson has the ability to explain complex principles and technologies in an easy-to-understand manner. There is a wealth of information in *Cinema Workshop* that every filmmaker who is serious about his craft must master. The presentation of

this material in *Cinema Workshop* is superb and makes the book well worth its \$8.95 cover price.

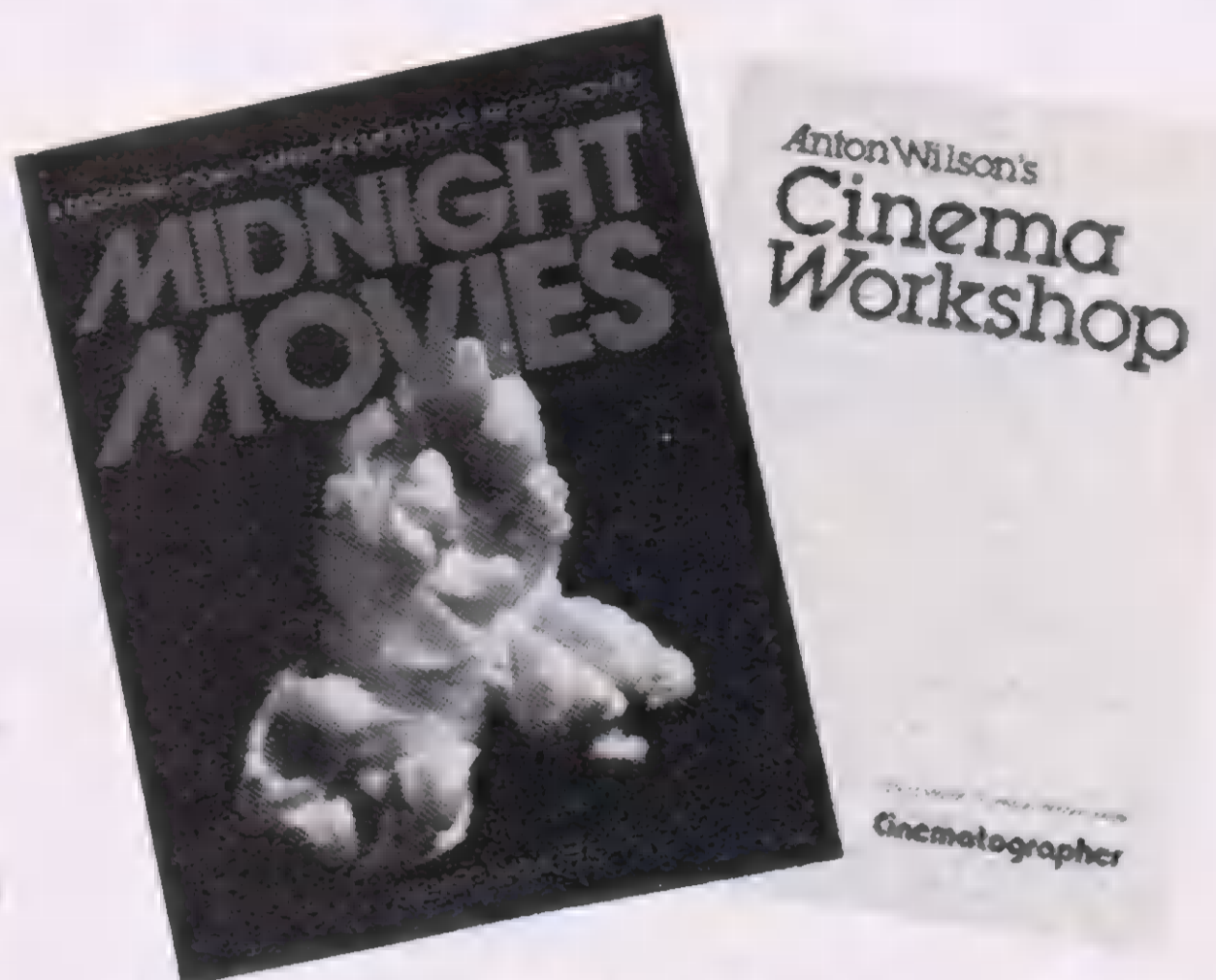

**Midnight Movies.** By Stuart Samuels. Collier Books, New York, NY, 8" x 10", 224 pages, \$9.95.

For over ten years, now, independent filmmakers have been taking advantage of a new phenomenon in motion picture exhibition—the midnight movie. Stuart Samuels' new book, *Midnight Movies*, chronicles the history of this modern day movie experience.

Beginning with Jodorowsky's *El Topo*, Samuels details the creation of this single man production (Jodorowsky wrote the script, directed the film in which he starred, composed the music, designed the costumes and built the sets; very much the same route the CINEMAGIC readers follow) and how it broke into theatrical exhibition via the art house and midnight movie circuit which was then being born in the depths of New York City.

Samuels also chronicles such films as Romero's *Night of the Living Dead*, Jimmy Cliff's *The Harder They Come*, the early *Reefer Madness*, John Waters' *Pink Flamingos*, the cult supported *Rocky Horror Picture Show* and David Lynch's *Eraserhead*. The book concludes with an analysis of the college circuit classics *Harold and Maude* and *King of Hearts*.

Of particular interest to CINEMAGIC readers are the stories behind the making of each film. Made for ridiculously low budgets, many of these films faced impossible production circumstances and would never have been made save for the dedication of their individual creators. The reader will gain a special insight into the life of the independent filmmaker and the trials that face him when it comes time for the finished film to be seen. Often getting the film before the public is much more difficult than raising money for the film or making the film itself. This special glimpse into a little-known world should be quite an eye-opener for CINEMAGIC readers. **CM**

## The extraordinary creator of *Star Wars* *Raiders of the Lost Ark* and *Revenge of the Jedi*

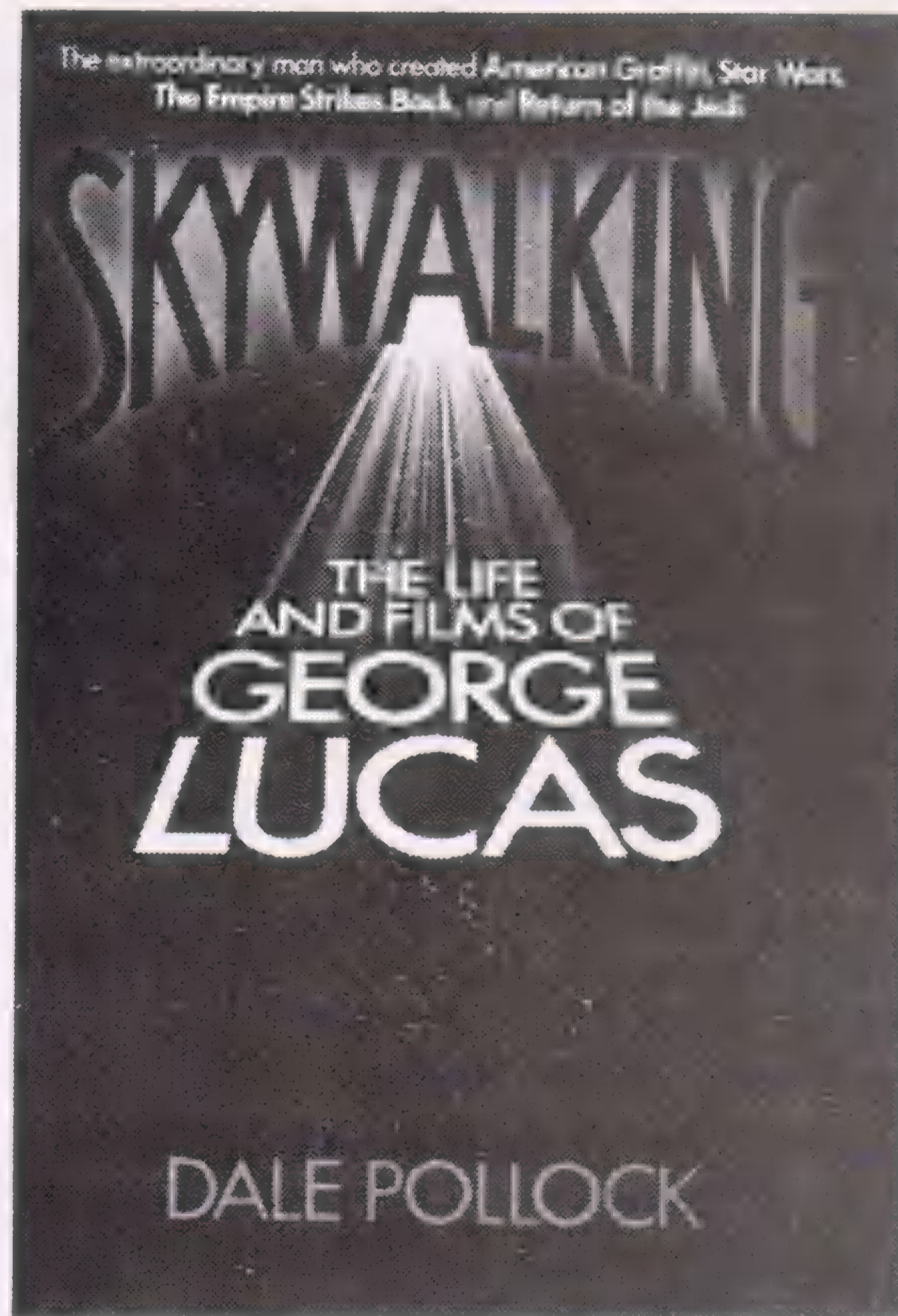

**Here is the first and only inside story of the quiet genius who's revolutionizing the American film industry. Illustrated with 30 photos.**

**\$14.95, now at your bookstore, or use coupon to order.**

**H·A·R·M·O·N·Y B·O·O·K·S**

—Clip and Mail—

**Send cash, check or money order to:**

**STARLOG PRESS  
475 Park Avenue South  
New York, NY 10016**

Please send me SKYWALKING: THE LIFE AND FILMS OF GEORGE LUCAS. I have enclosed \$14.95 for each copy ordered, plus \$1.40 to cover postage and handling. (Postage and handling for additional books: \$.50 per book.)

NAME \_\_\_\_\_

ADDRESS \_\_\_\_\_

CITY \_\_\_\_\_

STATE \_\_\_\_\_

ZIP \_\_\_\_\_

Allow 4 to 6 weeks for delivery.

# MAKING MEN INTO BEASTS

Makeup artist Alan Stacy talks about recreating 'Star Wars' creatures and designing an original werewolf costume.

By ALAN STACY

I think that it can easily be said that the makeup work in films of the past 10 years or so has managed to capture the imaginations of just about every ardent moviegoer. Some of the more creative efforts that caught my own eye over the years were Stuart Freeborn's man-apes from Kubrick's *2001: A Space Odyssey*, the various aliens appearing throughout the *Star Wars* saga and the like. A real favorite of mine is the beast from Jean Cocteau's 1947 *Beauty and the Beast (La Belle et la Bete)*. Nowadays, it seems that there is practically no limit to what makeup can accomplish; without a doubt this is what makes it so exciting. But as far as I'm concerned, there is no reason why the amateur makeup enthusiast cannot achieve something spectacular as well, and without spending too much money.

Stop-motion dimensional animation was what first got me interested in making my own films and doing makeup work as well. It has always seemed infinitely simpler to do things on a small, manipulable scale. But the patience required for dimensional animation taught me that the same degree of discipline was required for makeup work. My first efforts with makeup, like everyone else's, left a lot to be desired. I found the great "secret" to success lay in the willingness to stick with it through a vast amount of experimentation.

## WOOKIES

Doing reproductions of the *Star Wars* character costumes came to involve a great deal of time, effort and creativity. I had always been interested in making a "Chewbacca" costume simply because I had found the character to be very lovable and emphathetic, besides enjoying the appearance. The idea of doing the makeup work seemed very challenging to say the least. After a lot of discussions with friends and a great deal of encouragement, I decided to start.

For my "Chewbacca" costume I was fortunate enough to have a friend, Mark Word, who I considered tall enough to fit the role (6'5") and who was patient enough to undergo the casting of his head, hands and feet. He also had a very good-natured personality which seemed to mirror the film's character.

I obtained all the photographs I could that showed "Chewbacca" in every con-



The completed Chewbacca costume, worn by Mark Word, faithfully recreated by author Alan Stacy.

ceivable pose, various lightings, etc. From those, I evaluated Stuart Freeborn's outstanding creation. Once I decided the ratio between the costume for Peter Mayhew (the film "Chewbacca") and the costume, I would make it all boiled down to mathematics. A lot of sketchwork of the head, hands, feet and the body on the whole followed. The nose, mouth and head dimensions were of primary importance since these were the more detailed areas and subject to the greatest scrutiny. "Anatomically," this involved the padding and buildup of areas around the entire head, shoulders, chest and on the bottoms of the feet. The final height for Mark Word in my Wookiee costume was around seven feet.

Employing my knowledge of human and animal anatomy, I constructed what was the most difficult part first: the jaw

and its workings. The inner mechanism of the moving mouth required a little research into engineering principles: toggles, springs, etc. Also it required advice on mechanics from two other people. To contribute to the realism, the teeth were fashioned from dental acrylic after being sculpted in clay and cast in alginate. [Lang's Dental Acrylic Kit, available locally at Dental Supply Houses or from Lang Dental Manufacturing Co., Inc. Chicago, IL 60610. The Kit costs about \$12.00.] The palate (roof of the mouth) and lower jaw (with teeth inset) were also of acrylic, coated with colored latex in order to resemble the gums and musoca. A pre-colored foam latex tongue completed the mouth. The final functional jaw and mouth had undergone many revisions but a year later it is still functioning and in good shape.

The head itself was initially done in three pieces: front, back and lower lip and chin. All of these were assembled into one piece over the mouth apparatus. All of the head parts were done in foam latex. Throughout this entire project I used R & D Foam Latex colored with acrylics in the mixing. [R & D Foam Latex Kit RD 318C plus parts (\$33.00/gal.), R & D Latex Corp., 5901 Telegraph Rd., Commerce, CA. 90040.] You can use any brand of acrylic paints available at art supply stores, i.e. Hyplar, Liquitex, etc. I premix my colors to the desired shade separate from the foam mix, then add the color much like food coloring. This works well, but is "thin"—the acrylics are solvated with ammonia, which is compatible with latex, unlike water. The final head is a one piece slip-on with the jaw apparatus or mouth inserted separately.

The construction of the two piece body suit was simple enough since I had had enough experience with making close-fitting costume designs. The hair for Chewbacca is made of crepe wool. (Crepe Hair or Wool, in a wide range of colors at \$1.75/yd. For Chewbacca I used about 25-30 yards which comes to about \$50.00. Available from Paramount/Alcone, 575 Eight Ave., New York, N.Y. 10018.) The most time consuming factor in constructing the "Chewbacca" costume was the attaching and blending of the crepe hair onto the suit itself. One resulting problem is that the hair has to be combed out on occasion. Besides being very hot, the hair is constantly shed-



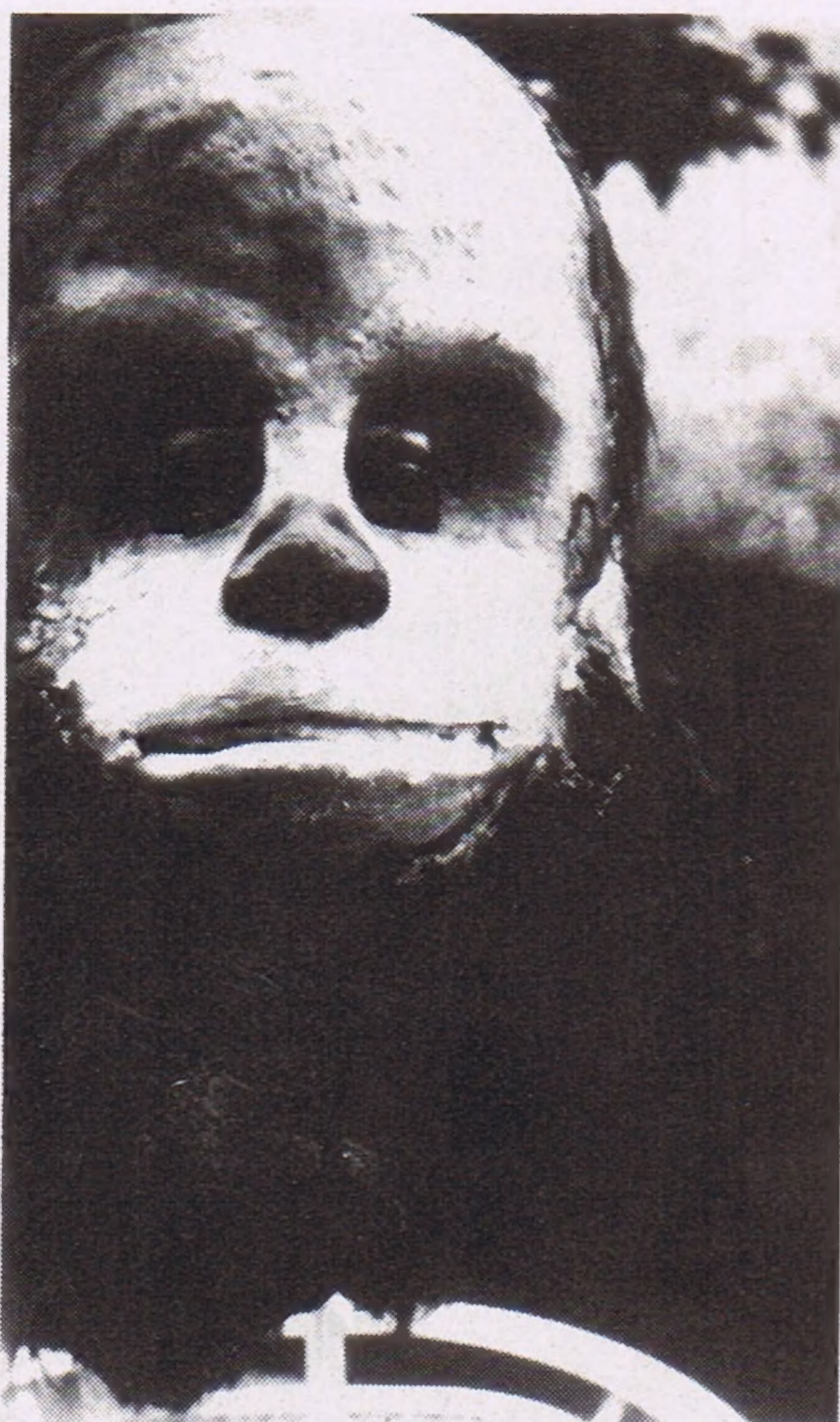

The Chewbacca head after the assembly of all of the parts. All that remains is to add the hair.

ding off, especially in warm weather!

The Chewbacca hands and feet are a combination of slush (Available from Paramount/Alcone, 575 Eighth Ave., New York, N.Y. 10018.) and foam latex (an outer "skin" of precolored slush latex) slip-on appliances. For the feet I employed a locally available heavy-duty mold-making latex compound. For the hands I used R & D; the mixture I used for the feet holds up nicely to constant wear. The design work for the feet was loosely modeled on purported Sasquatch ("Bigfoot")-type footprints appearing in the literature. [Grover S. Krantz *A Scientist Looks at the Sasquatch*, Univ. Idaho Press, 1978.] By this I mean the appearance of "Bigfoot" feet from plaster casts taken from impressions. The resulting Wookiee feet, with three inches of elevation, fit over Mark's own since I had embedded a positive cast of each of Mark's respective feet in the mold before adding the foam latex.

The accoutrements for Chewbacca, which includes the strap, or bandoliers, the pouch and the gun were another matter. The blocks were constructed from tubular aluminum and wood, painted to resemble chromed metal. The strap and pouch (people always ask what it contains) were from layers of canvas cloth glued together and lacquered to resemble leather, then dyed and stained to give it the appropriate "aged" or weatherized look. The gun was purchased from a company that specializes in reproducing *Star Wars* props and weapons. [Marco Enterprises, 293 Spruce Dr., Anaheim, Ca. 92805. Send \$1.00 for catalogue (check or money order).] The Chewbacca bowcaster cost about \$200.00, weighs, 8-10

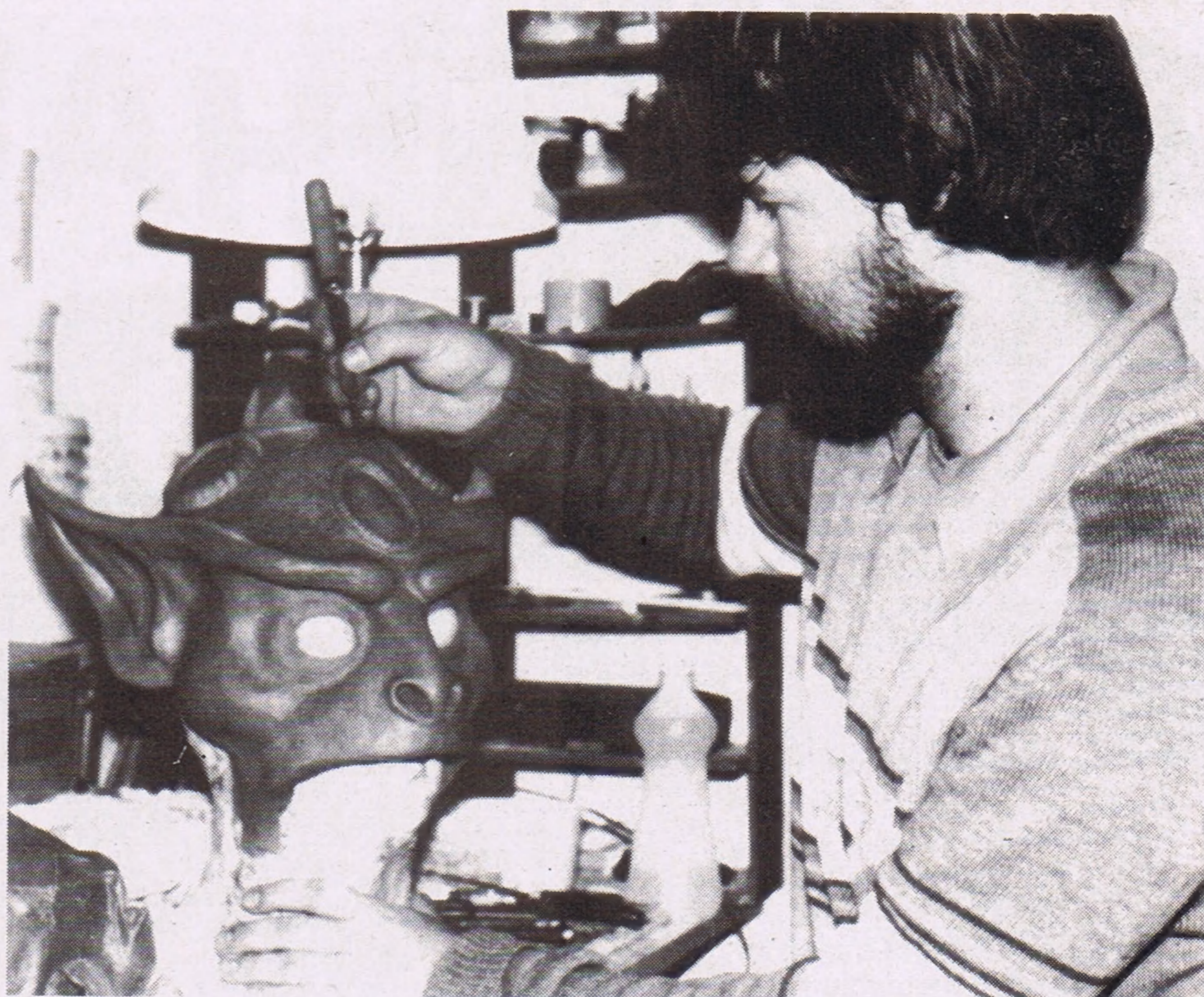

Author Alan Stacy at work in his studio. This is a current project that Alan is working on at the time of publication. Alan plans to make a full body suit and feature the creature in a film he has written.

lbs. and is not one of Mark's favorite props when he's dressed as "Chewie", because he's concerned he might accidentally hit someone with it.

## GREEDO

My reproduction of the Greedo character (Jabba's hit man sent to hunt down Han Solo, who was resurrected as Beedo in *Return of the Jedi*, again involved a lot of scrutinization of photos and sketchwork. The head was done in slush-latex, again colored with acrylics while liquid and cast in the slip fashion. The entire latex head was strengthened while still in the mold with "Celastic," an acetone

soluble, plastic impregnated cloth. ["Celastic" available from Paramount Theatrical Supplies, sold by the yard in varying weights, approximately \$10.00-15.00/yd.] The eyes were from spherical baby toys, cut in half and stained with blue glass stain. The Celastic strengthening was done in order to support the weight of the various additions such as the eyes, ears, etc. Two-piece molds were employed for the head, hands and feet with separate molds for the ears, antennae and bristles for Greedo's "mohawk". The hands and feet were sculpted over positives of my own hands and feet with "glove" appliances resulting. The costume itself, meaning the jumpsuit



Alan Stacy with part of his collection of home-made *Star Wars* creature re-creations and original creature makeup designs. In the foreground is Stacy's werewolf creation, an original design.

# ZOOMIN' OUT ATCHA! IN 3-D

SPECIAL  
3-D VIEWERS  
INCLUDED IN  
EACH BOOK.

## The Newest and Most Amazing **STARLOG** Photo Guidebook

STARLOG's special effects wizard, David Hutchison, has compiled a spectacular new addition to the famous STARLOG Photo Guidebook series of quality paperbacks. In one deluxe volume is a collection of the best articles on 3-D techniques, movies, comics, and much more!!!

- Complete index of 3-D comics & magazines!
- Complete guide to 3-D movies (credits, plots, etc.).
- How to make your own 3-D photos with any camera!
- Sources of 3-D equipment and supplies!
- 3-D books section!
- List of 3-D clubs worldwide!
- NASA/Mars 3-D photos!
- How 3-D TV works!
- History of 3-D!
- Movie special effects in 3-D!

This exciting 96-page book includes articles by 3-D experts on state-of-the-art technology and is illustrated with hundreds of photos and special art. "Fantastic 3-D" is the one authoritative volume covering every aspect of this incredible field.

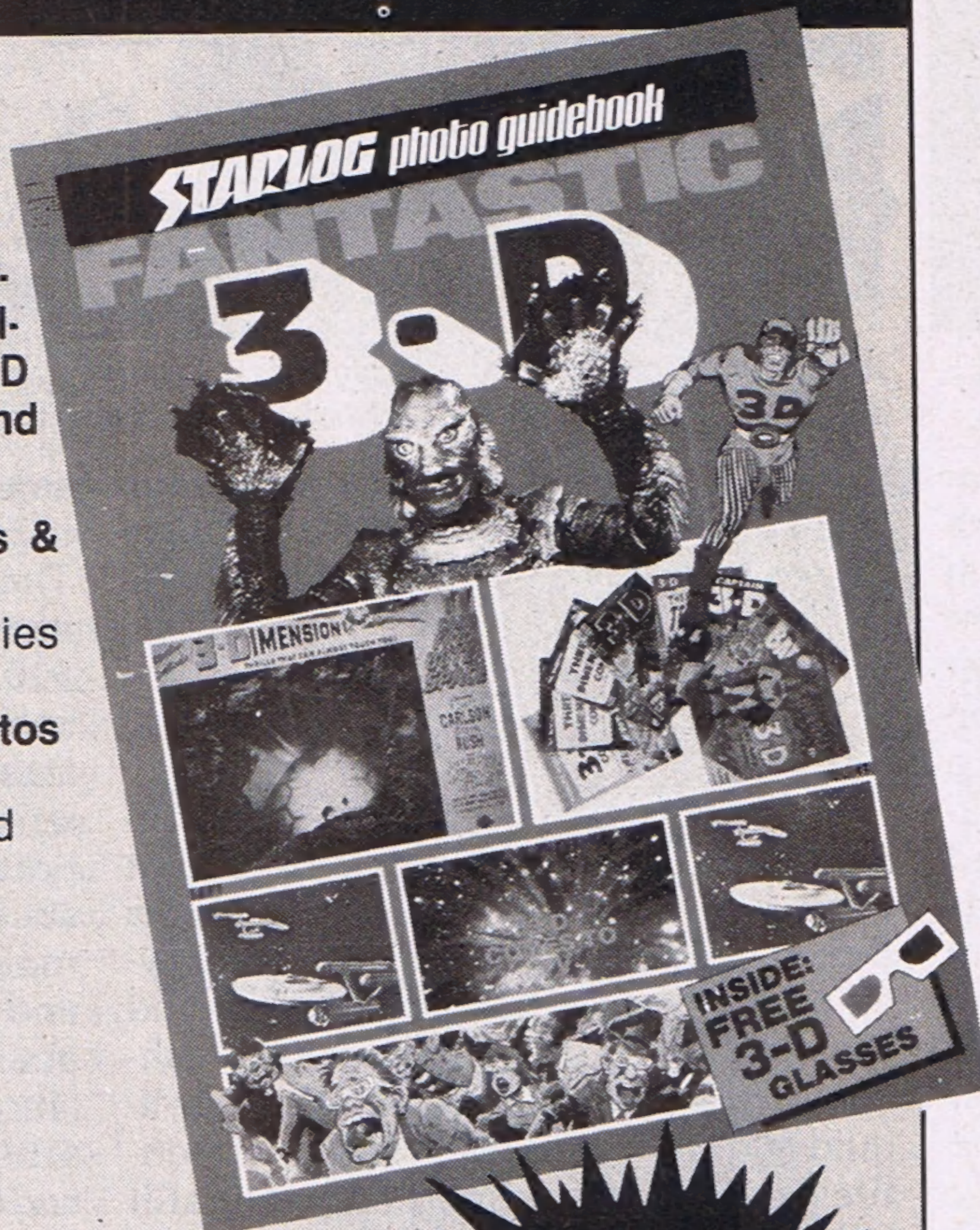

**ORDER YOUR  
COPY TODAY!**

\* Also available at  
Waldenbooks and other SF,  
comics and movie book stores.



The Tusken Raider costume shown here is one of two Stacy has made of the *Star Wars* character.

and vest, were done from my own patterns after studying the few photographs available.

Making Greedo was easier than Chewbacca and involved about 100 hours for the head, hands and feet. The jumpsuit and vest required about 20 hours of work. My total expenditure was \$50.00. For Chewbacca, about \$300.00 went into his manufacture alone (counting the gun). About one gallon each of slush and foam latex were needed for the various appliances. On a time schedule basis, I started construction of the Chewbacca costume in April of 1982. Most of the work had been completed by the middle of June. The time spent was well in excess of 500 hours.

### WEREWOLF

Since that time I have moved on to involving myself in producing original designs. The werewolf costume shown was done on a whim. The features were sculpted over my own, with the head, hands and feet done in foam latex, with a skin of slush latex molded first. The claws and teeth were fashioned from "Sculpey" and mounted into preformed grooves. The body suit was padded along the arms and shoulders, the fur was the so-called "fake fur" (Available from Paramount Theatrical Supplies at about \$8.00 per

Please rush \_\_\_\_\_ copy(ies) of  
"FANTASTIC 3-D" at \$11.95 each, plus  
postage.

#### ADD POSTAGE:

\_\_\_\_\_ 3rd Class . . . . . \$1.55 ea.

\_\_\_\_\_ 1st Class . . . . . \$1.75 ea.

\_\_\_\_\_ Foreign Air . . . . . \$2.50 ea.

Total enclosed: \$ \_\_\_\_\_

NYS residents must add sales tax.  
Please allow 3-6 weeks for delivery.

Send cash, check or money order to:

**STARLOG 3-D**  
475 Park Ave. South  
New York, NY 10016

NAME \_\_\_\_\_

ADDRESS \_\_\_\_\_

CITY \_\_\_\_\_

STATE \_\_\_\_\_ ZIP \_\_\_\_\_



PHOTOS: COURTESY OF ALAN STACY



Stacy made this Greedo costume because he was tired of going to science fiction conventions without a costume to hide behind. It cost \$50 and took 120 hours.

This original werewolf was sculpted over life casts of Stacy's own features, resulting in a perfectly-fitting creation. In it, Stacy has appeared on local cable TV.

yard) for the body, hands, face and feet. Eventually my friends and I used the costume for a video-tape which was run on a local cable TV station. We were rewarded with an enthusiastic response; the tape was run numerous times after its original airing. It just goes to prove that makeup can be fun.

Without a doubt, makeup work is a thinking process. You must be able to visualize what your goals will ultimately mean in terms of time, effort and money. Be realistic with yourself but don't be too hard on yourself if your efforts don't turn out perfect or the way you planned them. You must take the time to sit down and do the work, whether sculpting or casting. You can't rush anything if you want good results. It is important that you enjoy what you're doing—otherwise you'll be wasting your time. Finances are always needed, but there is no reason to go out and spend a lot of money for something just because that might be "what Rick Baker uses" or "what they did in *Star Wars*." Shop around by all means!

Most important of all, you must follow through and finish your projects once you've begun. It requires that you discipline yourself not to get "burned out" on something no matter how discouraged or frustrated you become. I have met and talked with a lot of people who have seen

my works, and are interested in doing this kind of work. Very unfortunately, they might give up about one-third of the way through their projects, saying "it's already been done better by someone else." So what? Usually the lack of determination comes from a lack of confidence or a lack of understanding of what you're doing and what it takes to finish the project. So I'm back to my first point: you have to think it out first!

Many people for some reason believe that imitation is easy. It might be from

certain standpoints such as design. But consider this: you must learn at least as much as the original artist did in order to emulate his creations, or understand just what it took for he or she to do it. Granted there are shortcuts for just about anything, but you can only skimp so much before a haphazard job starts to become obvious. The greatest indicator of any sort of effort on your part is the end product itself. If you're happy with what you've achieved you're bound to please others as well. It's that simple! **CM**

Some of Stacy's friends wearing *Star Wars* costumes that he recreated for them. From left to right they are: Alan Stacy in Greedo costume; Mark Word in the Chewbacca costume; Bob Klem in a Rebel Trooper costume; Mark Fisher in a Luke Skywalker -Dagobah costume; M. Roden in a Leia costume (Stacy did not make this costume); Tom Copeland, age 12, in a Jawa costume; and P. Roberts in a Han Solo costume.



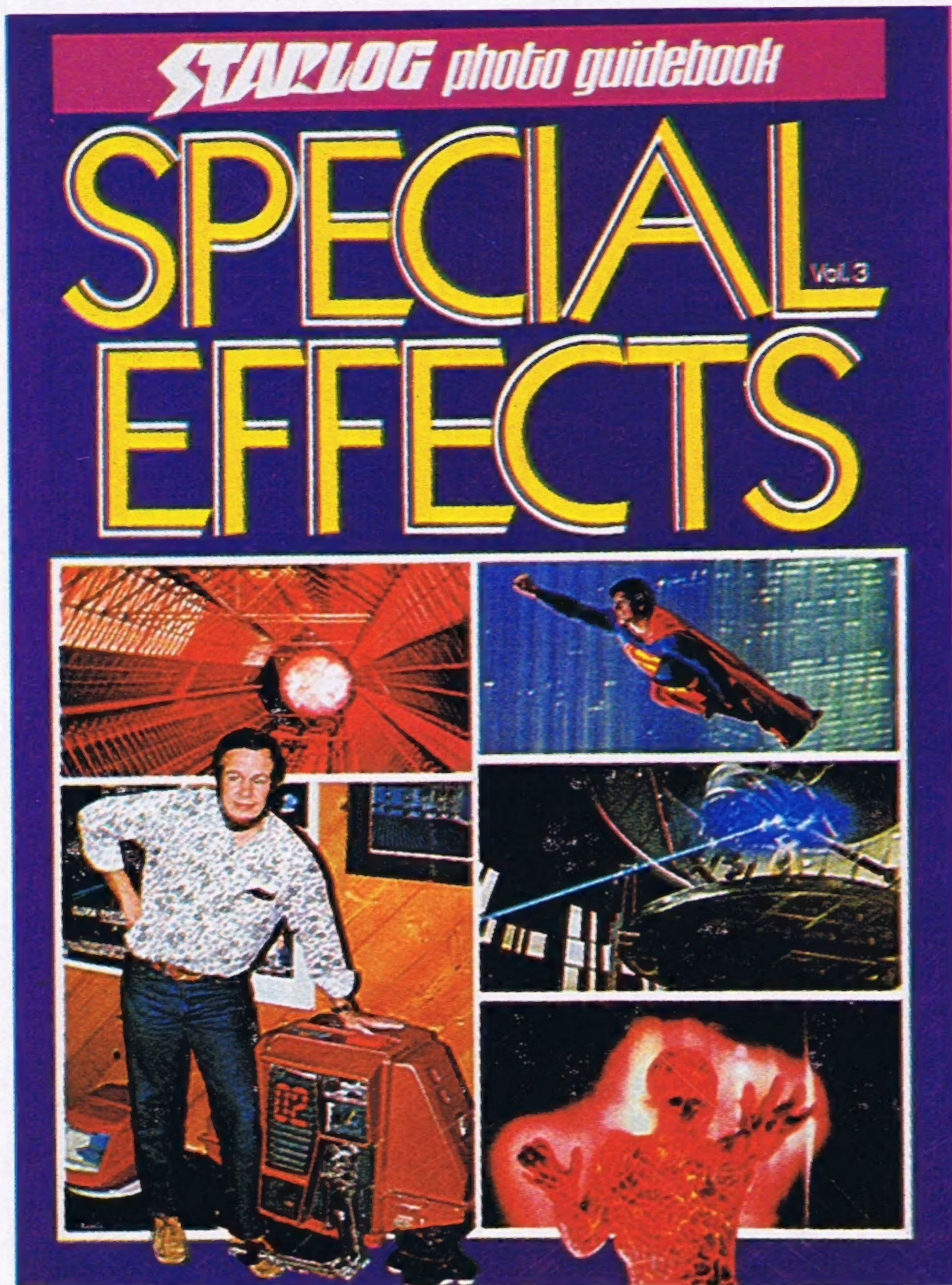

## NEW!

### HIGH-TECH FILMMAKING!

Just published, this newest volume in the STARLOG Photo Guidebook series on Special Effects takes you on a trip into the gleaming world of modern film wonders—the technologies that create Hollywood's special effects for science fiction, horror and fantasy movies. In this exciting book you'll read about computer animation, robot cameras and new optical processes. SPECIAL EFFECTS, Vol. 3 lets you visit the shops of many of the technical artists who make the "impossible" their everyday job. Lavishly illustrated with page after page of photos (many in full color) this new book takes you on the sets of recent films like *Star Wars*, *Flash Gordon*, *ALIEN*, *The Empire Strikes Back*, *Altered States*, *The Black Hole*, TV's *Dr. Who*, *Cosmos*, and more! Discover the innerworkings of Doug Trumbull's new ShowScan process and the new double-70mm 3-D system. If you are interested in filmmaking, here, in one volume, is your chance to learn about present-day techniques in special effects—and also glimpse what the future holds.

### SFX SECRETS

#### SPECIAL EFFECTS, Vol. 1

See the amazing world of miniatures and model animation—from *King Kong* to Ray Harryhausen and TV's *Land Of The Lost*. Special blueprint section includes: the Nautilus from *20,000 Leagues Under The Sea*, Robby the Robot, the C-57D flying saucer from *Forbidden Planet*. Behind-the-scenes color photos from *Battlestar: Galactica*, *Space: 1999*, *The Lost Saucer* and SF classics like *Close Encounters*, *Flight To Mars*, *Thunderbirds*, *War of the Worlds*, *Star Trek* . . . more!

#### SPECIAL EFFECTS, Vol. 2

Exclusive interviews with masters of matte painting, effects, make-up and cel animation. A festival of effects films from space epics to splatter movies—pictured in color photos and technical diagrams. Special section on making the giant squid from Disney's *20,000 Leagues Under The Sea*, the Time Machine from George Pal's movie, and the Enterprise designs—from TV to theatrical. All this . . . plus more!

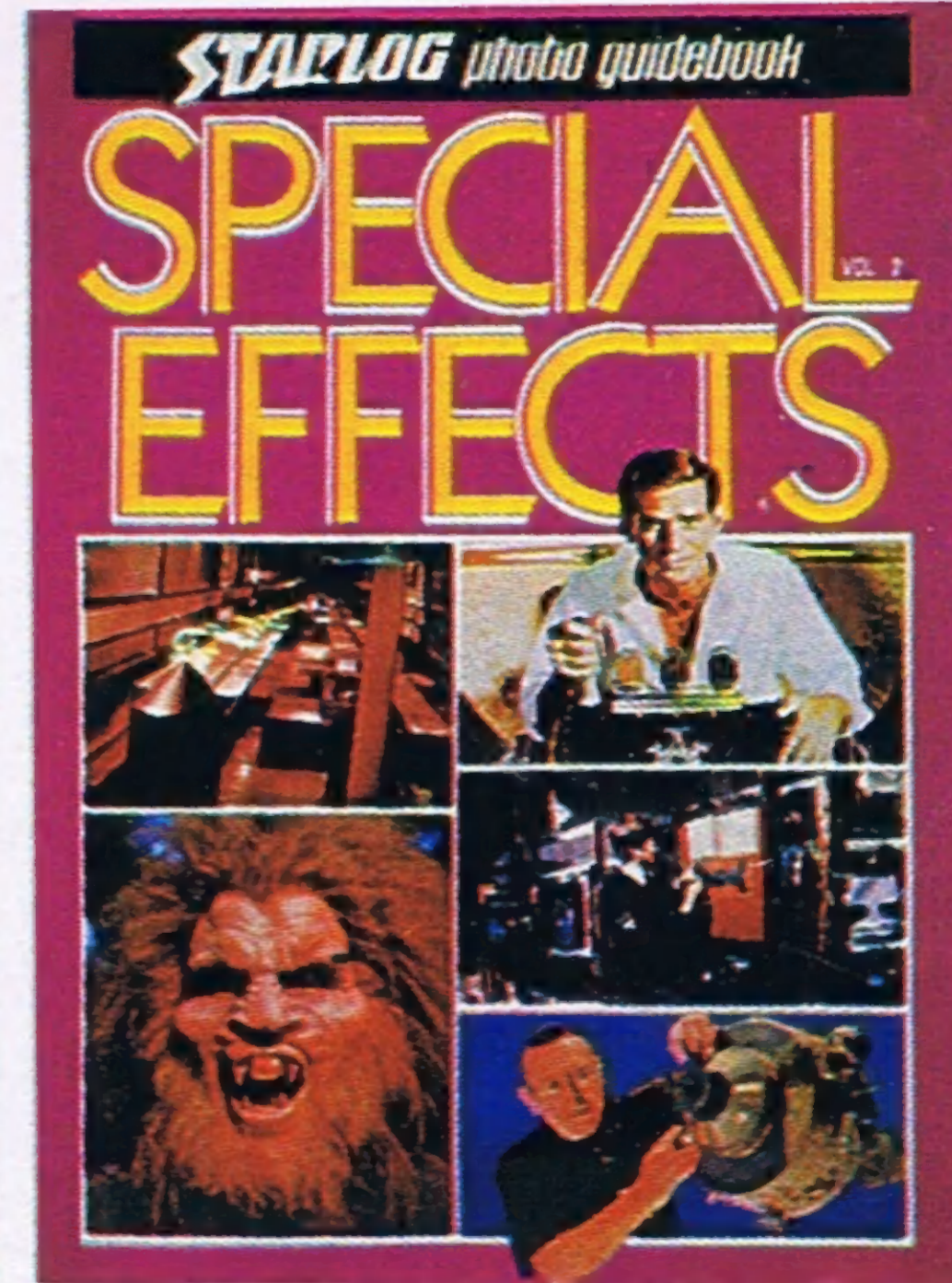
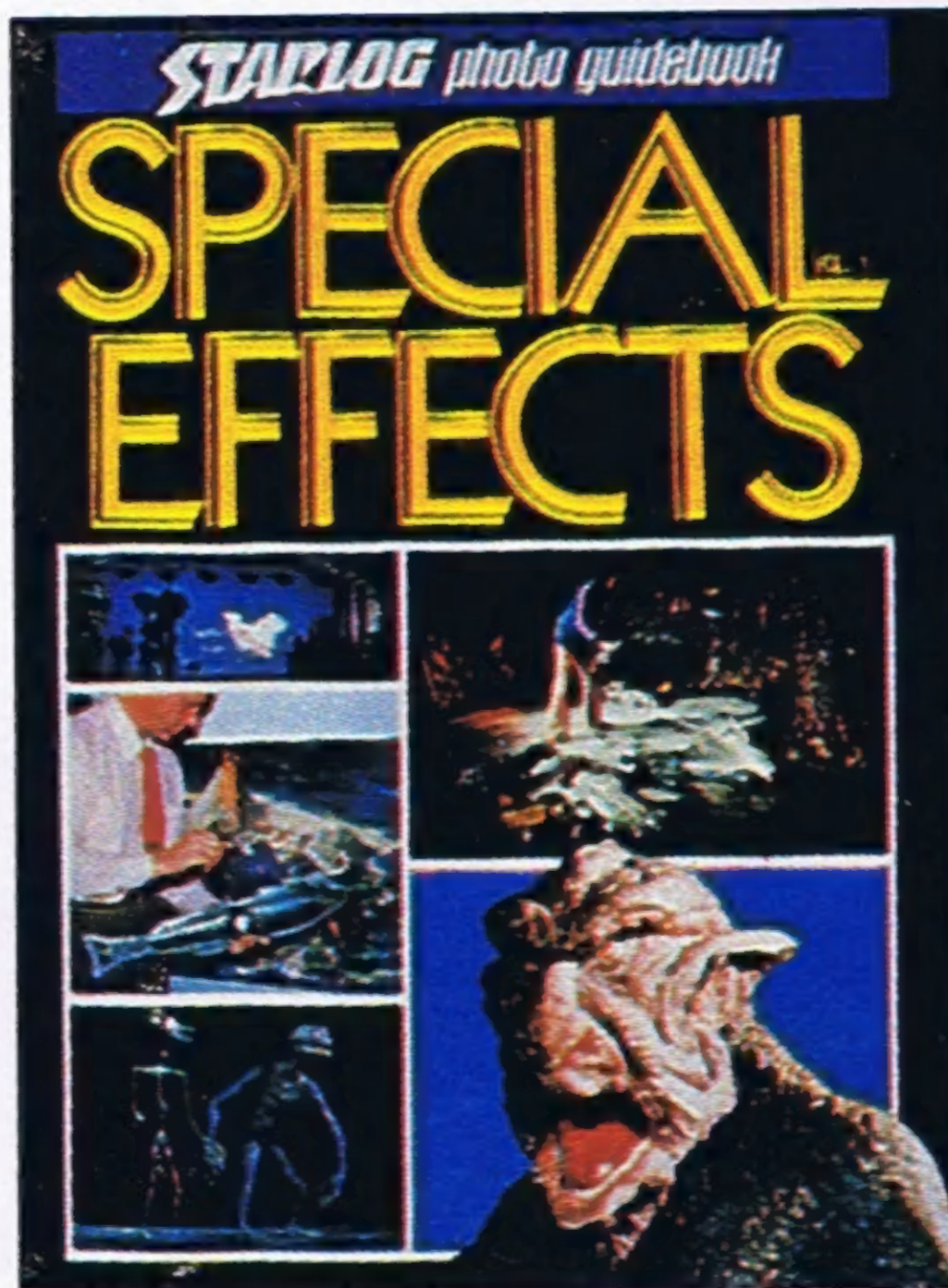

Add postage to your order:

Send to:  
STARLOG GUIDEBOOKS  
475 Park Avenue South  
New York, NY 10016

total enclosed: \$ \_\_\_\_\_  
NYS residents add sales tax  
Please allow 4 to 6 weeks for delivery of 3rd Class  
mail. First Class delivery usually takes 2 to 3 weeks.

Name \_\_\_\_\_  
Address \_\_\_\_\_  
City \_\_\_\_\_  
State \_\_\_\_\_ Zip \_\_\_\_\_

SPECIAL EFFECTS	
Vol. I .....	\$6.95
Vol. II .....	\$7.95
Vol. III .....	\$8.95
Add Postage for Above:	
3rd Class .....	\$1.55 ea.
1st Class .....	\$1.75 ea.
Foreign Air .....	\$2.50 ea.

**ORDER NOW!**